



**CITY OF NANAIMO
PUBLIC ART
STREET BANNER DESIGN PROGRAM 2025**

CALL TO ARTISTS AND DESIGNERS

ISSUE DATE: June 14th, 2024

DEADLINE: 11:59pm PST | August 26th, 2024

ABOUT THE STREET BANNER DESIGN PROGRAM

The City of Nanaimo is seeking designs for its 2025 street banner program.

This program offers artists and designers an opportunity to submit proposals for original banner artwork that will be hung in Nanaimo's downtown area. Banners will be put on display in spring 2025, in the Arts District downtown, along Bowen Road, Third Street and other major routes, creating a vibrant visual presence.

The selected applicant will receive an honorarium of \$2,500 for their banner design. Fabrication and installation costs are covered by the City and are not included in this fee.

Eligibility

This program is open to artists and designers at all levels of experience, currently living in British Columbia.

THEME: Metamorphosis & Change

How do things change? How do they stay the same? The world around us is ever-transforming. Living on Canada's west coast we bear witness to a landscape in constant transformation, but change extends beyond that of our physical environment. In our community, in our families, in our personal relationships, in our daily connections, change is ubiquitous. For this year's banner theme we ask you to reflect on the concept of metamorphosis and change.

Submissions to the 2025 Street Banner Program under this theme might reflect positive instances of change and transformation in our community and/or world at large, illustrate metamorphosis and change in nature, creatively combine concepts of change and transformation in disparate settings, and consider the ways in which art and culture provoke change, awakening new perspectives and ideas.

2025 Street Banners are encouraged to illustrate creative responses to this theme. Highly graphic elements are suggested, and artists must be prepared to adapt their proposed design to accommodate specifications for best print quality.

How to Apply

The applicant is responsible for offering a design that illustrates their own interpretation of the theme. The City of Nanaimo will be responsible for the fabrication and installation of the banners.

Applicants must supply:

- 1) A completed application form
- 2) A written statement about your proposed design, and how it supports the banner theme (one page).
- 3) A biography (up to 350 words)
- 4) Your CV / resume
- 5) A colour rendering of your design. The banners are printed using digital files, so while you may submit an original sketch, computer-generated images must be rendered of your design idea. Please follow the format outlined in the design specifications below.

For submissions, we accept digital images in JPG, PDF or TIFF format.

For production, we will need vector files in a scalable vector format, usually PDF or EPS.

Note: You can propose up to three (3) different banner designs (1 design includes left and right banners) in your submission. Only one design will be selected.

Design Specifications

Banner Dimensions

mini street banners 18" W x 42" L

full-size street banners 34" W x 80" L

banner sleeve 3.25" on top and bottom edge

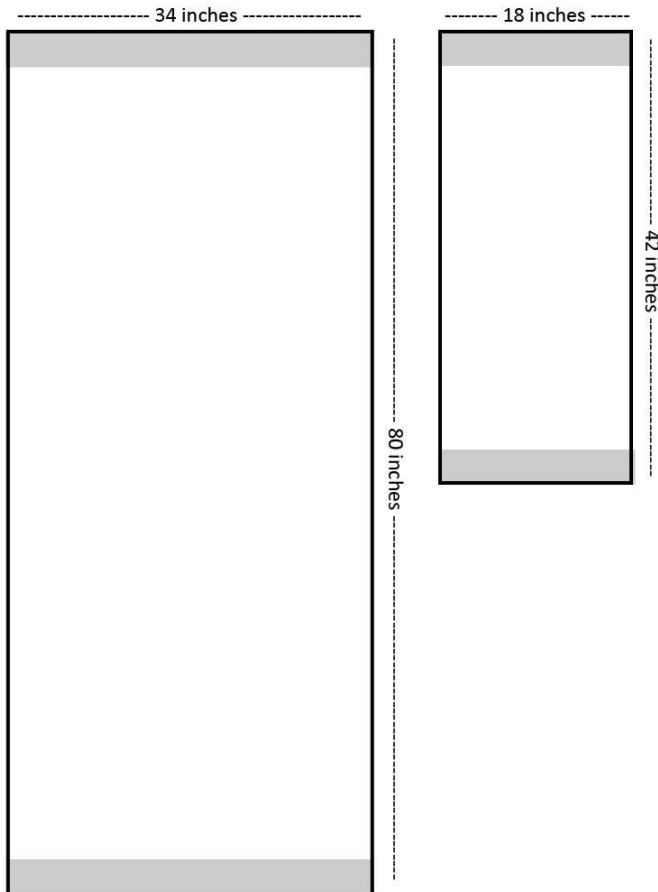

Street Banner Installation

Avoid adding any important design elements on the upper and lower 3.25" banner sleeve

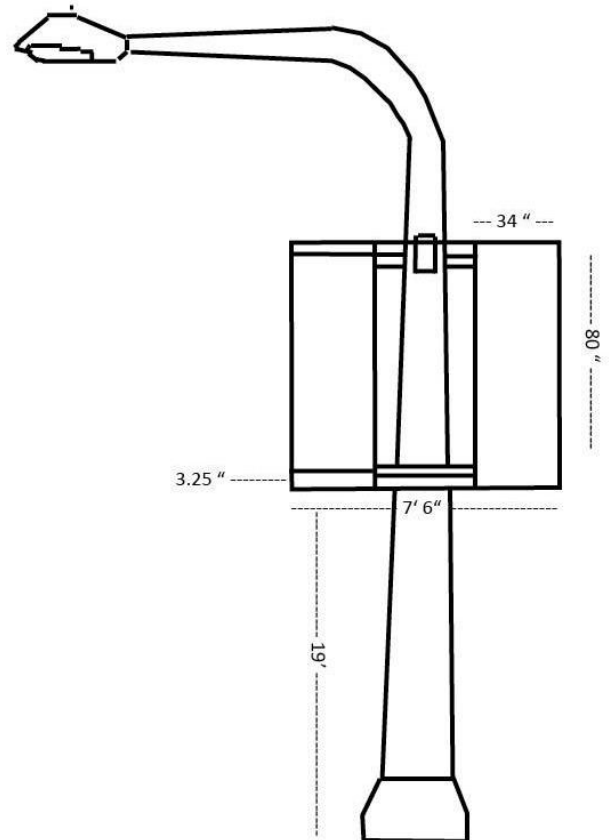

Colour

The colour scheme for the 2025 competition is open. We strongly suggest high contrast, and a palette of no more than five highly chromatic colours containing maximum hue, plus black, white and grey.

For best print quality, we would recommend avoiding shading techniques. However, gradient colours can be achieved.

Best print results come from colours and images that take advantage of light passing through fabric. Designs should take into consideration that colours fade over the season. Darker colours typically hold their colour in outdoor settings over time much better than light or pastel colours.

Contrast

When creating your design, consider the effects of a colour combination on design legibility and visual interest. Examples below are for demonstration only and do not indicate colour preference.

EFFECTIVE CONTRAST	POOR VISUAL CLARITY
LOW CONTRAST LOW VISIBILITY	HIGH VISIBILITY COLOUR CHOICE

Other Design Considerations

- Designs must be effective from long viewing distances and short viewing duration. Small details and complicated designs are not generally effective. Take into account that banners will be viewed from the road at speeds of up to 50 km per hour.
- Banners should consider the surrounding streetscapes.
- Designs must be non-commercial in theme.
- Designs must be original.
- Designs may use a diptych approach (design split into 2 panels).
- **We don't encourage using words or letters in your design.** If you are using lettering in your design, choose a font size and style that can be read at a distance of 50 to 75 feet. Note that words will appear in reverse on one side of the banner.

DESIGNS THAT INCORPORATE LOGOS WILL NOT BE ACCEPTED.

Selection and Award

A selection panel formed by the City will review all proposals. Designs are reviewed based on the following criteria (order listed does not indicate the order of importance):

- Originality and creativity
- Quality / Effectiveness of Design
- Uniqueness of style
- Degree to which the design reflects the theme

The applicant whose banner design is selected will receive an honorarium of \$2,500, to be paid upon provision of the final design.

Selected Designs: Next Steps

A selected banner design will be announced when the competition is complete. The final design is scheduled to be sent to the Supplier responsible for banner production by November 15th, 2024, with final production slated for completion by end of January 2025. The artist may be required to make modifications to their design prior to production according to the production particulars below. The artist will agree to a guaranteed **response time of 48 hours** (made within office hours, 9:00 AM – 5:00 PM (PST), Monday – Friday excluding Public Holidays) to support requests by the City and/or the Supplier.

Production Particulars

The selected design will need to be produced as a high quality digital vector format (.ai .eps .pdf) or as .jpg files that are saved at each required print size, with a resolution of 300 dpi. If the file is not a vector format, each element of the drawing should be saved on a separate layer, with colours in solid coated pantone format identified for the production proof stage. The production team will review the files and make minor colour adjustments for colour fastness. A final production proof will be generated for artist review.

Copyright

The successful participant will retain copyright of their design and will grant the City license to use the selected design for the purpose of creating the street banner and for non-commercial promotional materials. At the end of the installation period, banners will be removed and when possible, made available for public sale.

How to Submit your Proposal

Submissions must be received no later than **11:59pm, Pacific Time, August 26th, 2024**. There are two ways to submit your design:

1. Submit your application and required documents **online** using the form (see below); or
2. Drop off your application and required documents **in-person** to the Culture & Events Dropbox, located at the Bowen Complex, 500 Bowen Road. The Dropbox is located on the lower level of the building near the tennis courts (Pine Street Entrance). Hand-delivered applications MUST:

Include a complete package must include one (1) original hard copy. The application must be enclosed and sealed in an envelope/package clearly marked:

Your Name
Street Banner Program 2025
City of Nanaimo
Culture and Events

Terms and Conditions

Once submitted, the application is subject to the *Freedom of Information and Protection of Privacy Act*. The City advises applicants that submissions may be subject to the provisions of *FOIPPA* and the *Community Charter*. Personal information provided in the submission will be collected pursuant to *FOIPPA* and the *Community Charter*. Personal information will not be released except in accordance with the *FOIPPA*. Questions about the collection of your personal information may be referred to the Legislative Services Department at (250) 755-4405, or via email at foi@nanaimo.ca.

Questions

Thank you for your interest! Applicants will only be contacted if their design is chosen. Questions regarding the Street Banner Program may be directed to Culture & Events at cultureandevents@nanaimo.ca ATTN: Street Banner Program, or 250-755-4483.

Application Form

Applicants must complete this form in addition to providing the attachments noted in the checklist below. Please ensure all information is legible.

1.	Full Name	
2.	Address (include postal code)	
3.	Phone #	
4.	E-mail Address	

Attachment Checklist

- A written statement about proposed design, and how it supports the banner theme (one page)
- A brief biography (up to 350 words) and CV
- A colour rendering of design. You can propose up to three (3) different banner designs as one single submission. Designs may be an original sketch, painting or computer-generated image of the design idea, following the format outlined in the design specifications below. We will accept digital images in JPG, PDF or TIFF format on flash drive or via remote upload.

I acknowledge that I understand and agree with the terms of the Street Banner Program process as described in this program guideline, and I verify the information included in the submission is complete and correct.

Applicant Signature

Date

Examples of Previously Selected Banners



Amy Pye, 2024



Sebastian Abboud, 2023



Roz MacLean, 2022



Becky Thiessen, 2021