

CIVIC ADDRESS 1720 DUFFERIN CRESCENT, NANAIMO, BC
 LEGAL DESCRIPTION LOT 1, SECTION 15, RANGE 8, MOUNTAIN DISTRICT, PLAN EPP9933

ZONING RM-3
 DENSITY CALCULATION

LOT AREA SQ.M	17,981
LOT AREA SQ.FT.	193,546
MAX FAR	0.45
MAX FA SQ.FT.	87,096

UNIT TYPE	# OF UNITS	SQ.FT./UNIT	GFA
TYPE A MID	2	1,014	2,028
TYPE A MID JOG	4	1,020	4,080
TYPE A END	4	1,014	4,056
TYPE B MID	6	1,256	7,536
TYPE B END	9	1,264	11,376
TYPE C1 MID1	4	1,332	5,328
TYPE C1 MID2	2	1,381	2,762
TYPE C1 END	4	1,343	5,372
TYPE C2/C3 END	9	1,343	12,087
TYPE C2/C3 MID1	9	1,332	11,988
TYPE F1	6	1,684	10,104
TYPE F2	6	1,684	10,104
	65		86,821

LOT COVERAGE AND BUILDING HEIGHTS
 MAX COVERAGE 40%
 MAX SQ.FT. 77,418

BUILDING #	COVERAGE SQ.FT.	GROSS COVERAGE SQ.FT.	HEIGHT (FT-IN)
BUILDINGS 1 & 2	3,097	6,194	27'-3/4"
BUILDINGS 3 TO 5	3,807	11,421	28'-9 3/4"
BUILDINGS 6 & 7	4,299	8,598	26'-8 1/2"
BUILDING 8 to 16	1,682	15,138	26'-8 1/2"
BUILDING 17 to 22	2,499	14,594	29'-2 1/2"
		56,345	

PARKING

STALLS / UNIT	REQUIRED	PROVIDED
# STALLS TOTAL	108	130
# DISABLED	4	4
# VISITOR	5	5

DRAWING LIST

- A1.0 SITE PLAN
- A1.1 TYPE A
- A1.2 TYPE B
- A1.3 TYPE C1
- A1.4 TYPE C2
- A1.5 TYPE C3
- A1.6 TYPE F
- A1.7 GARBAGE ENCLOSURE AND MAIL BOX



LOT 1
 9006 SQ. m + 8975 SQ. m

AMENITY SPACE

GARBAGE ENCLOSURE (REFER TO A17)

MAIL BOX (REFER TO A17)

SPRINKLER/ELECTRICAL CLOSET

PARK

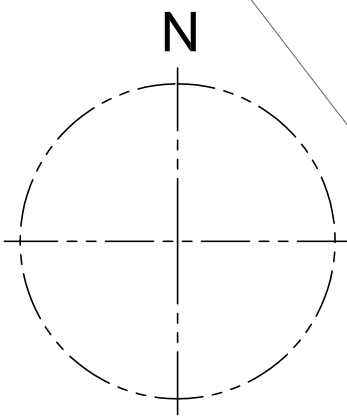

P1 SITE PLAN
 A1.0 SCALE: 1" = 20'-0"

COPYRIGHT RESERVED. ALL PARTS OF THIS DRAWING ARE THE EXCLUSIVE PROPERTY OF ANDREW TERRETT ARCHITECT & ASSOCIATES AND SHALL NOT BE USED WITHOUT THE ARCHITECT'S CONSENT. THE CONTRACTOR SHALL REPORT ALL ERRORS AND OMISSIONS TO THE ARCHITECT, AND VERIFY ALL DIMENSIONS ON SITE BEFORE PROCEEDING WITH THE WORK. DO NOT SCALE DRAWINGS.

REVISIONS:

rev.	date	description
1	FEB 07/11	CONSULTANT COORDINATION
2	MAR 04/11	DEVELOPMENT PERMIT
3	APR 12/11	DEVELOPMENT PERMIT AMENDMENT
4		
5		
6		
7		
8		

SEAL:

CONSULTANT:

PROJECT:
 1720 Dufferin Crescent
 NANAIMO, BC

SHEET TITLE:
 LOCATION PLAN

CHECKED BY: AT
 DRAWN BY: CV
 DATE: JAN 12/11
 SCALE:

PROJECT NO. DRAWING NO.
 A1.0

COPYRIGHT RESERVED. ALL PARTS OF THIS DRAWING ARE THE EXCLUSIVE PROPERTY OF ANDREW TERRETT ARCHITECT & ASSOCIATES AND SHALL NOT BE USED WITHOUT THE ARCHITECT'S CONSENT. THE CONTRACTOR SHALL REPORT ALL ERRORS AND OMISSIONS TO THE ARCHITECT, AND VERIFY ALL DIMENSIONS ON SITE BEFORE PROCEEDING WITH THE WORK. DO NOT SCALE DRAWINGS.

REVISIONS:

rev.	date	description
1	FEB 07/11	CONSULTANT COORDINATION
2	MAR 04/11	DEVELOPMENT PERMIT
3		
4		
5		
6		
7		
8		

SEAL:

CONSULTANT:

PROJECT:

**1720 Dufferin Crescent
NANAIMO, BC**

SHEET TITLE:

**BUILDING 1 AND 2
TYPE A**

CHECKED BY: AT

DRAWN BY: CV

DATE: JAN 12/11

SCALE: 1/8" = 1'-0"

PROJECT NO. DRAWING NO.

A1.1

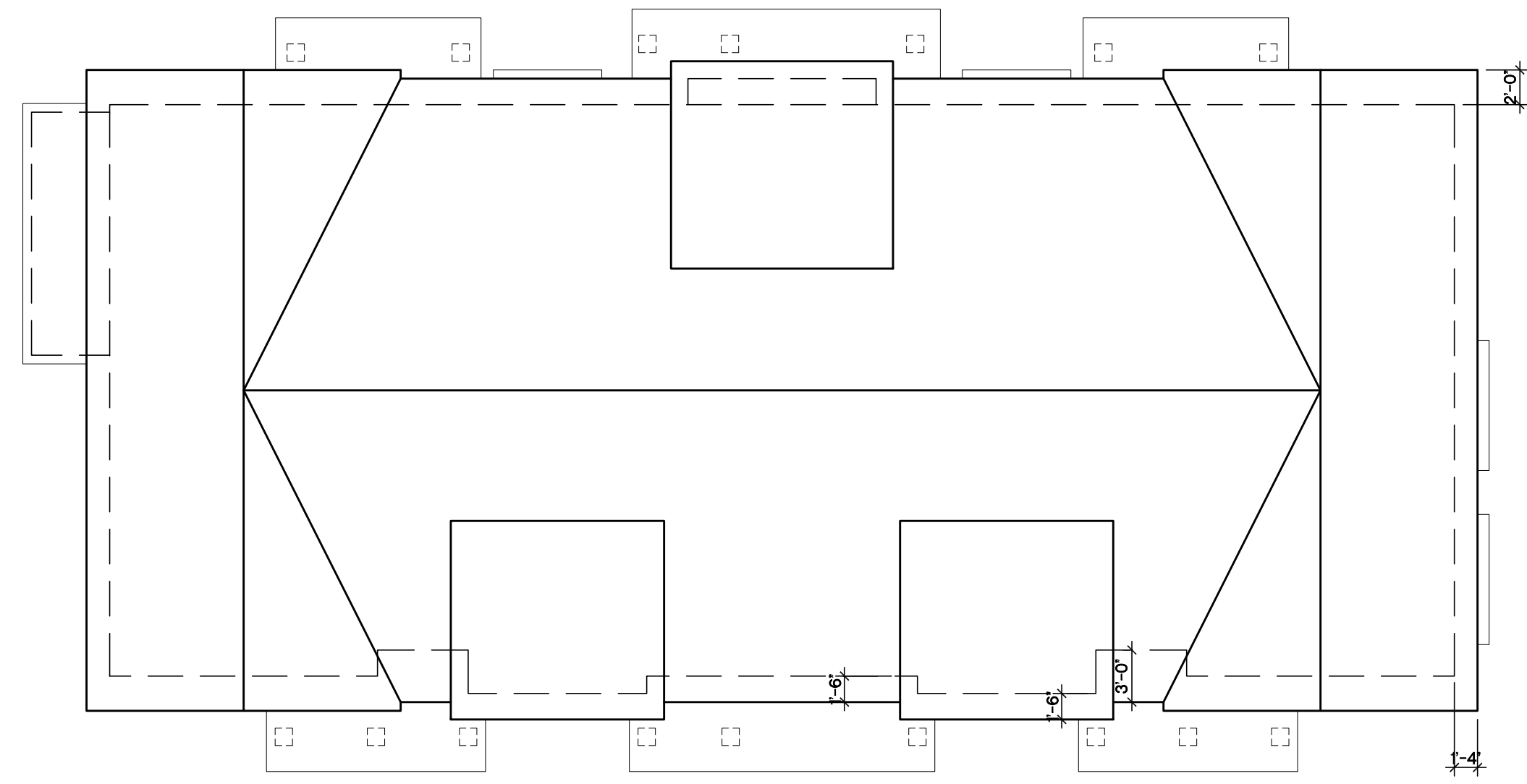
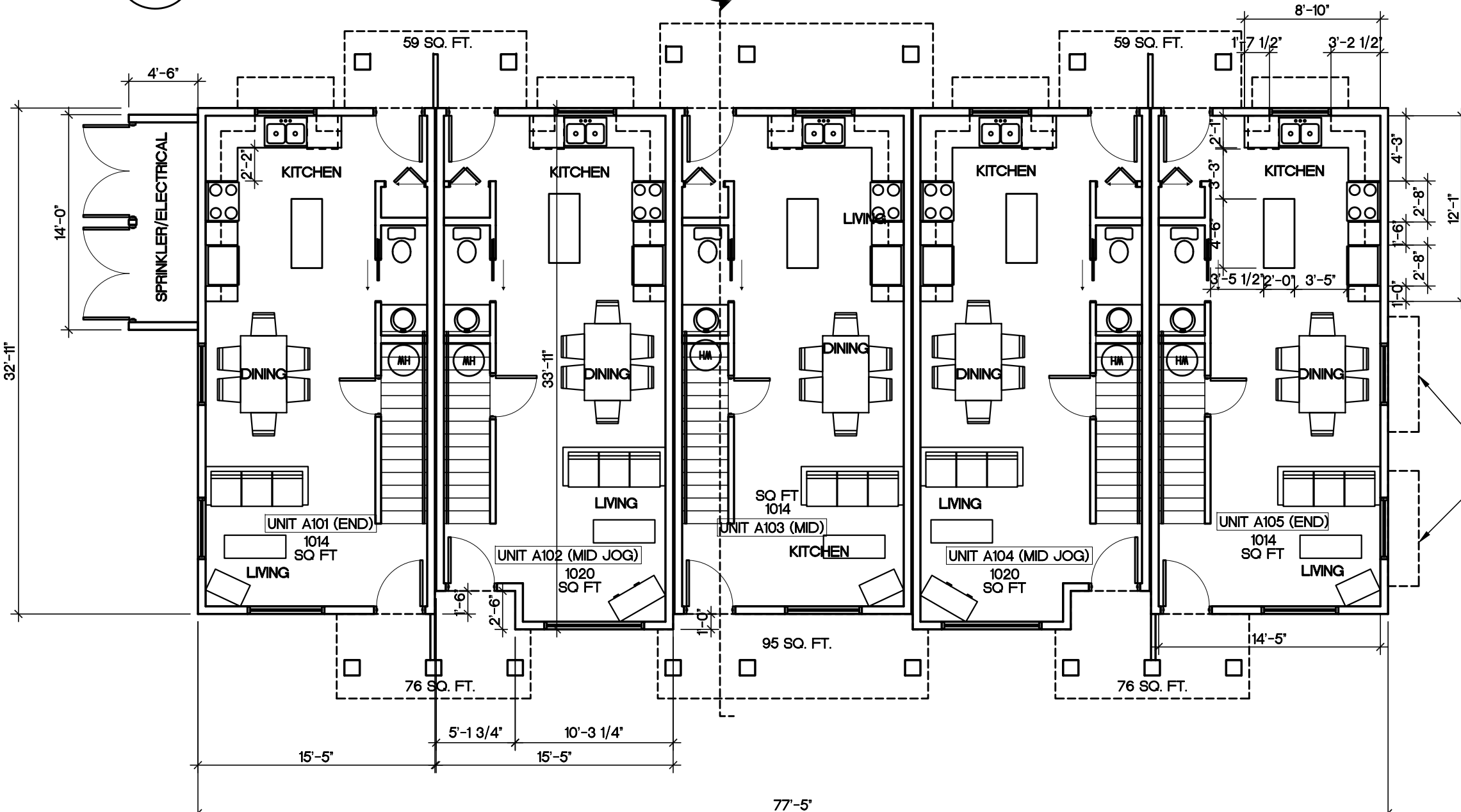
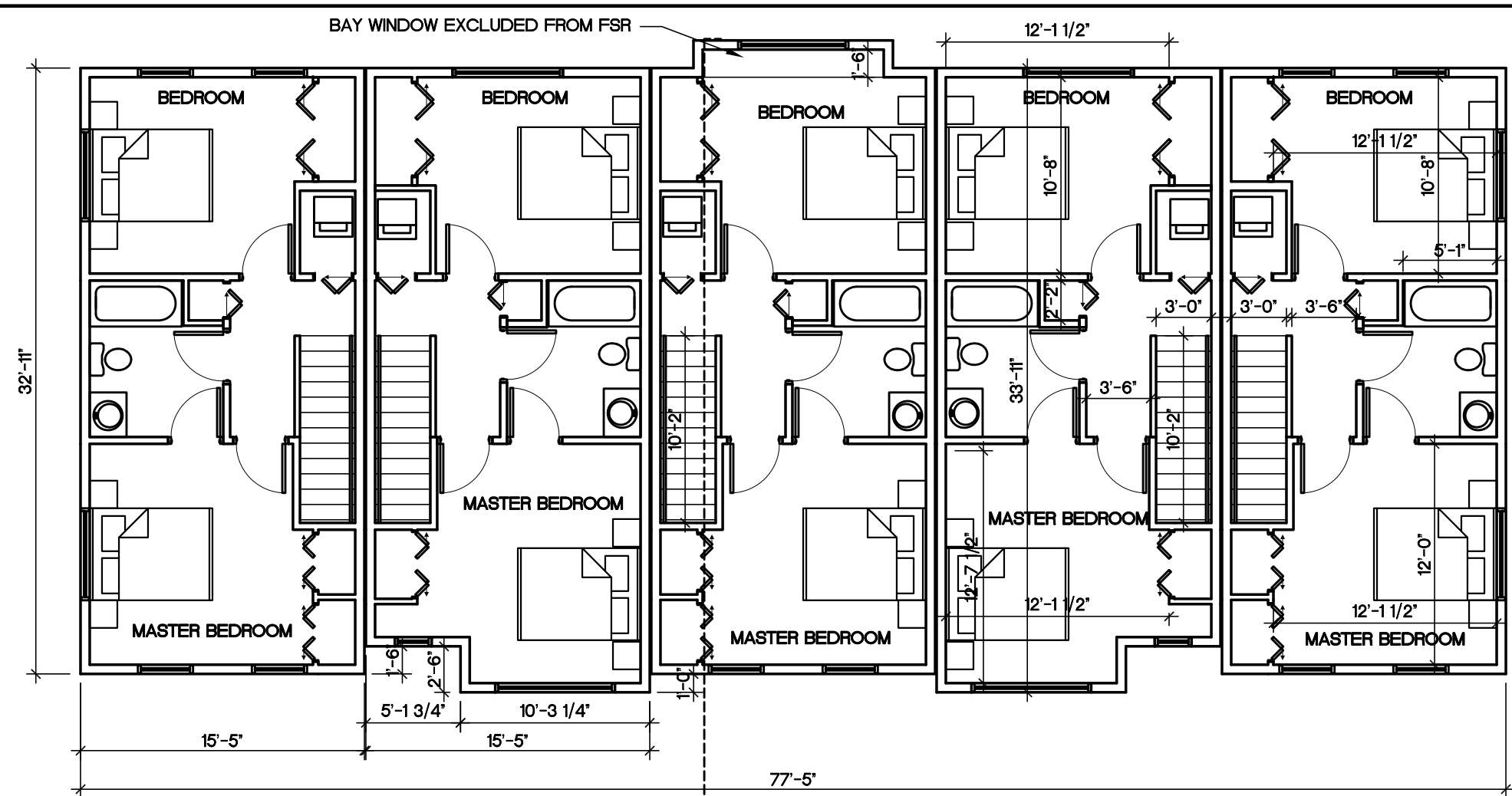

SHED ROOF ON EAST SIDE OF BUILDING 3 AND WEST SIDE OF BUILDING 1 ONLY (REFER TO SITE PLAN). NO SHED ON EITHER SIDE OF BUILDING 2.

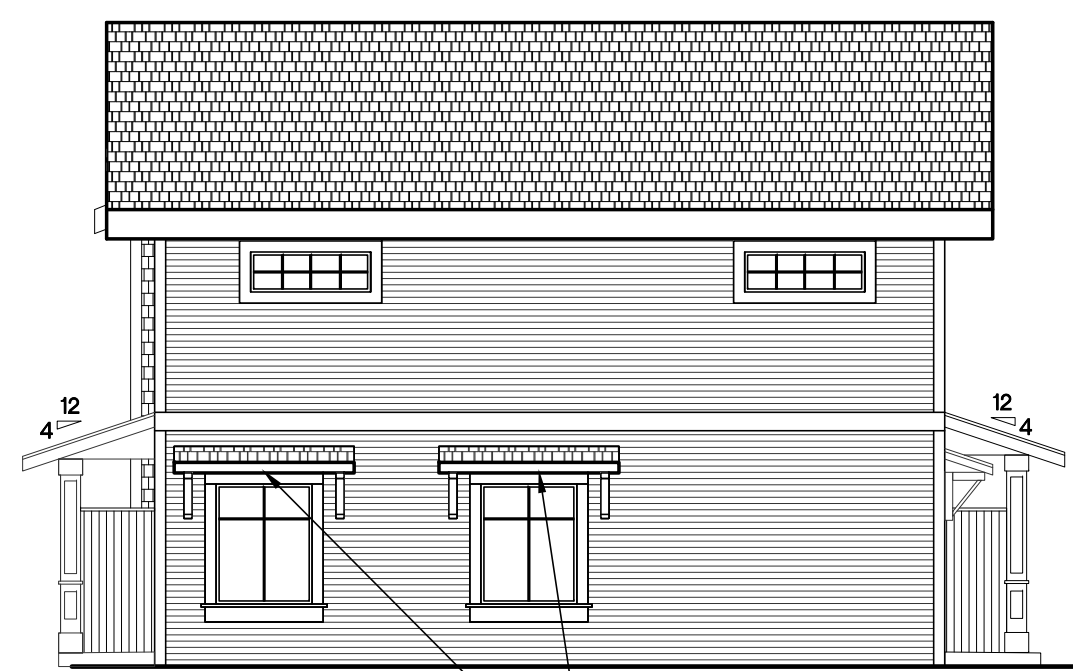

SHED ROOF ON EAST SIDE OF BUILDING 1 ONLY

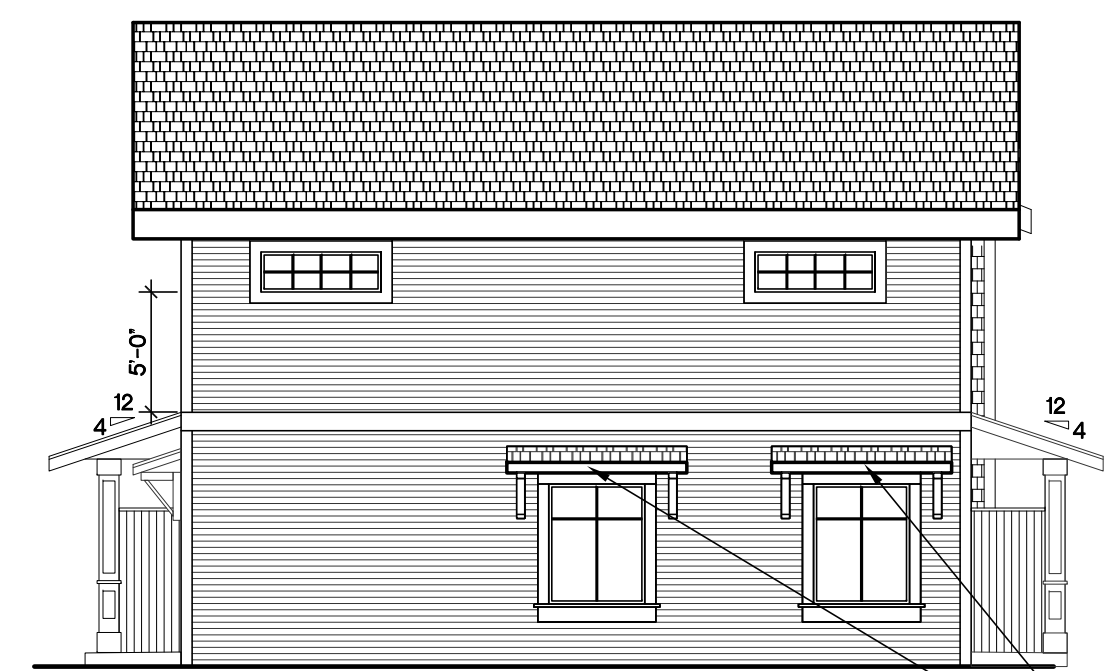

SHED ROOF ON WEST SIDE OF BUILDING 1 ONLY

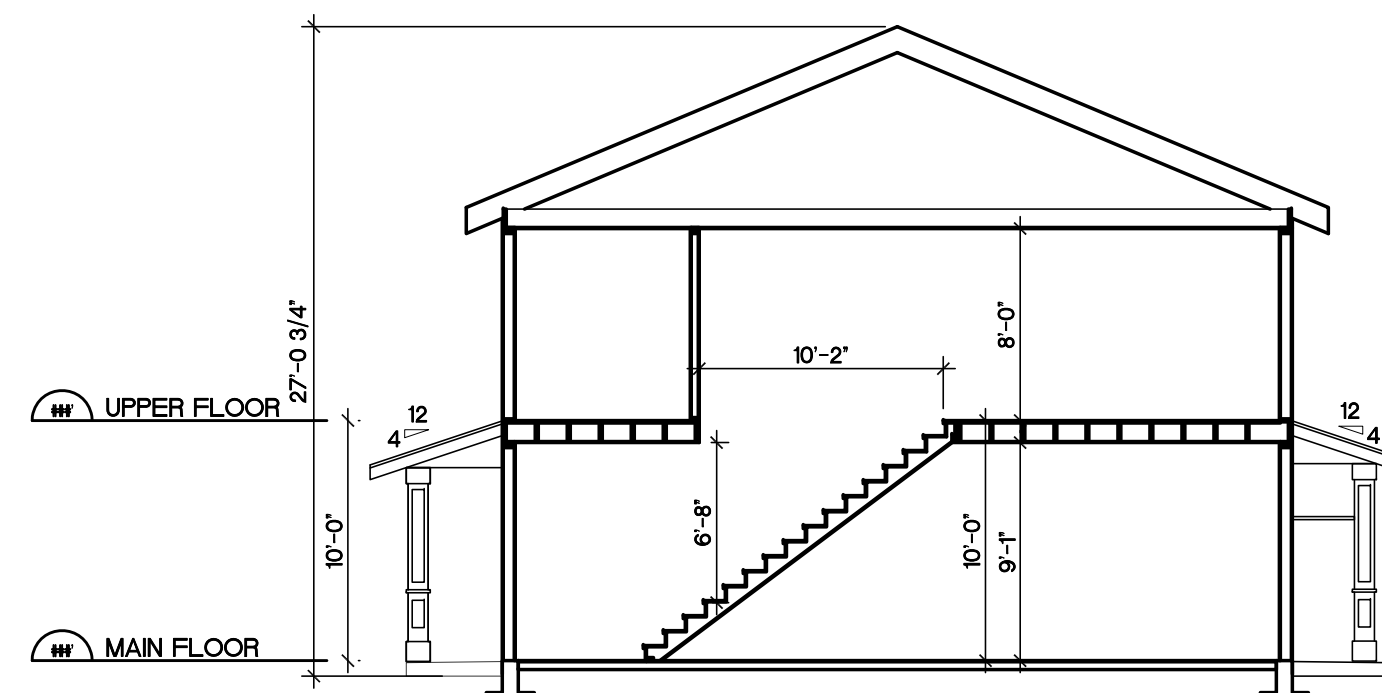

COPYRIGHT RESERVED. ALL PARTS OF THIS DRAWING ARE THE EXCLUSIVE PROPERTY OF ANDREW TERRETT ARCHITECT & ASSOCIATES AND SHALL NOT BE USED WITHOUT THE ARCHITECT'S CONSENT. THE CONTRACTOR SHALL REPORT ALL ERRORS AND OMISSIONS TO THE ARCHITECT, AND VERIFY ALL DIMENSIONS ON SITE BEFORE PROCEEDING WITH THE WORK. DO NOT SCALE DRAWINGS.

REVISIONS:

rev.	date	description
1	FEB 07/11	CONSULTANT COORDINATION
2	MAR 04/11	DEVELOPMENT PERMIT
3		
4		
5		
6		
7		
8		

SEAL:

CONSULTANT:

PROJECT:

1720 Dufferin Crescent
NANAIMO, BC

SHEET TITLE:

BUILDING 3, 4 AND 5
TYPE B

CHECKED BY: AT

DRAWN BY: CV

DATE: JAN 12/11

SCALE: 1/8" = 1'-0"

PROJECT NO. DRAWING NO.

A1.2

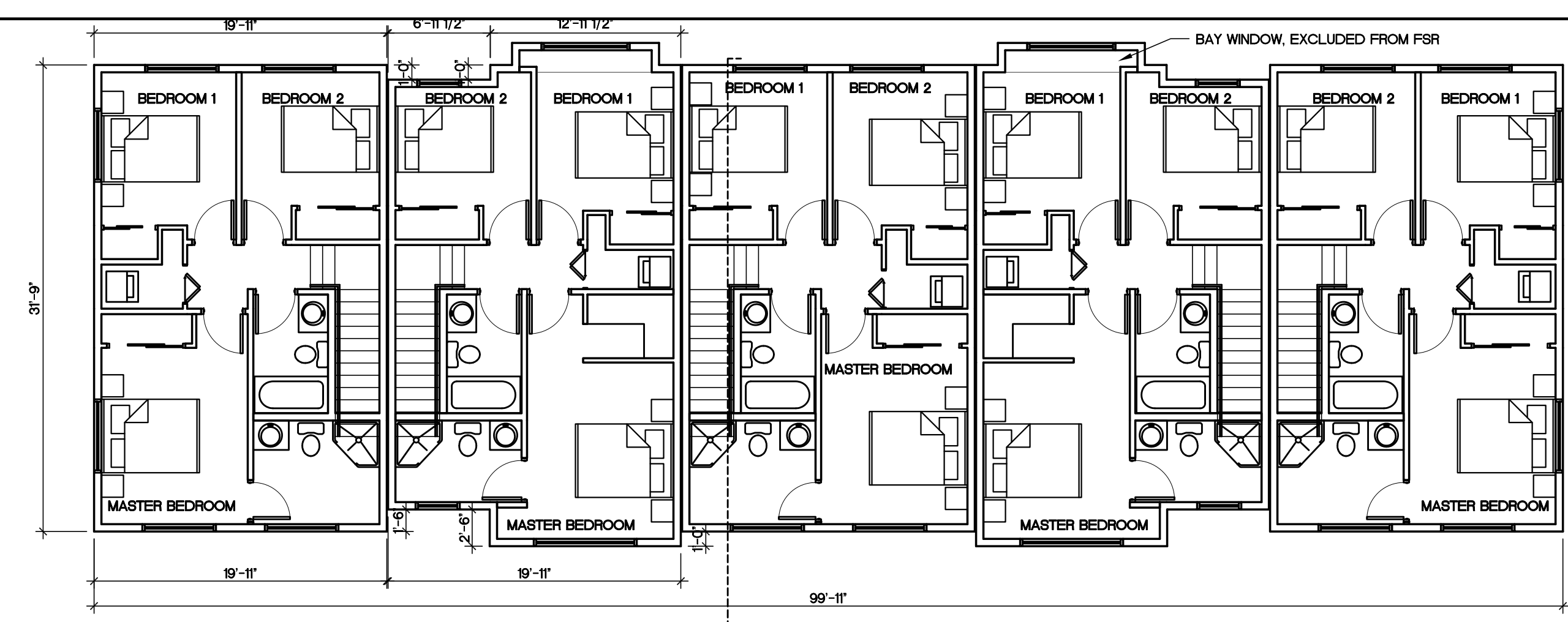

P2
A1.2 2ND FLOOR PLAN
SCALE: 1/8" = 1'-0"

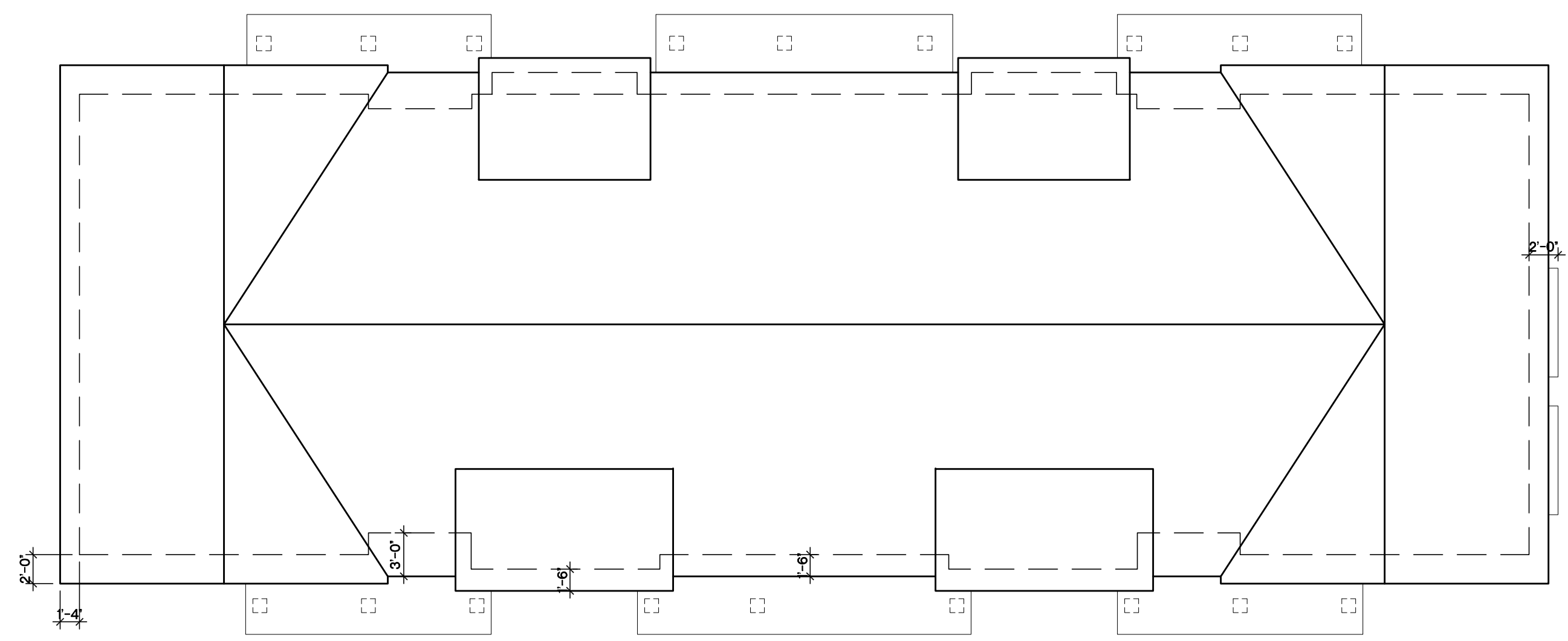

TYPE B ROOF PLAN

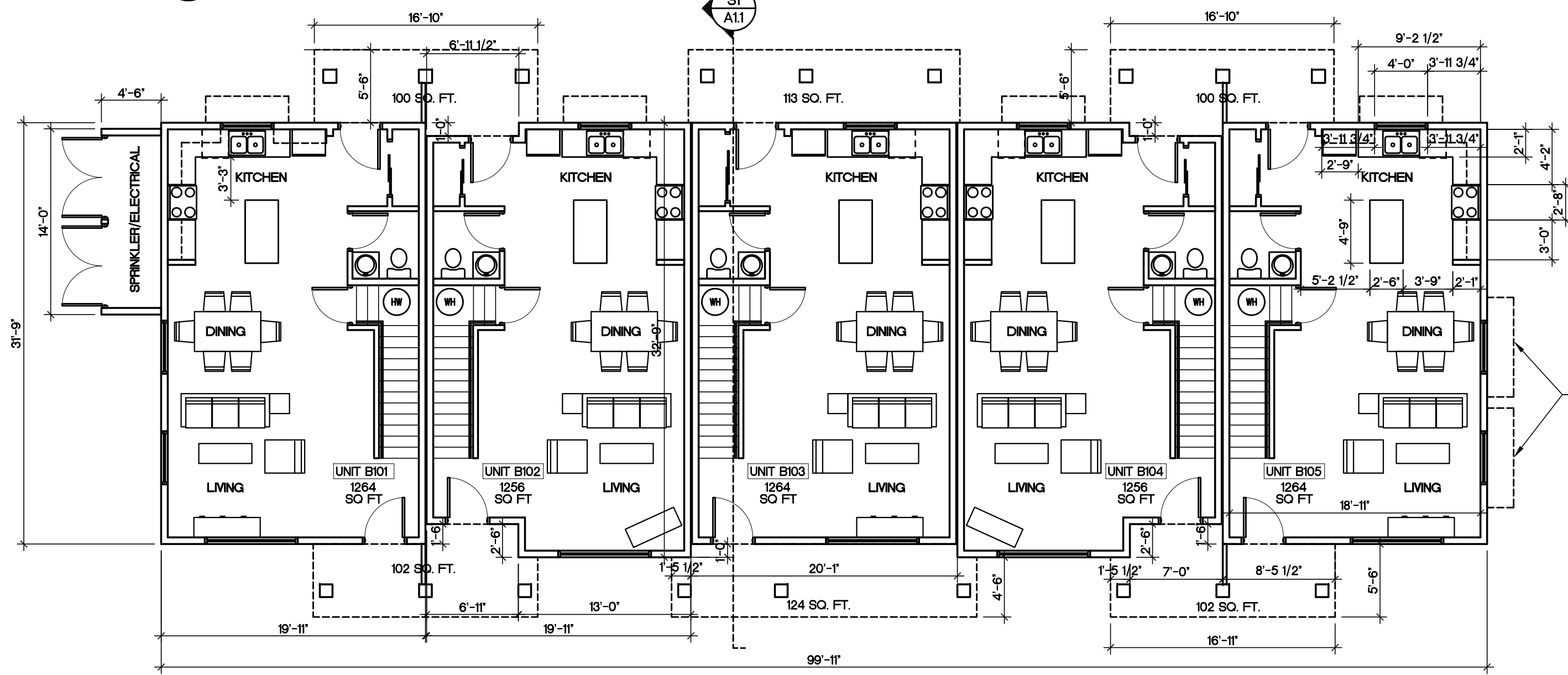

P1
A1.2 GROUND FLOOR PLAN
SCALE: 1/8" = 1'-0"

CONFIRM SIZE WITH KITCHEN DESIGNER

SHED ROOF ON WEST SIDE OF BUILDING 6 ONLY (NO SHED ON EITHER SIDE OF BUILDING 5)



E1
A1.2 FRONT ELEVATION
SCALE: 1/8" = 1'-0"



E2
A1.2 SIDE ELEVATION
SCALE: 1/8" = 1'-0"

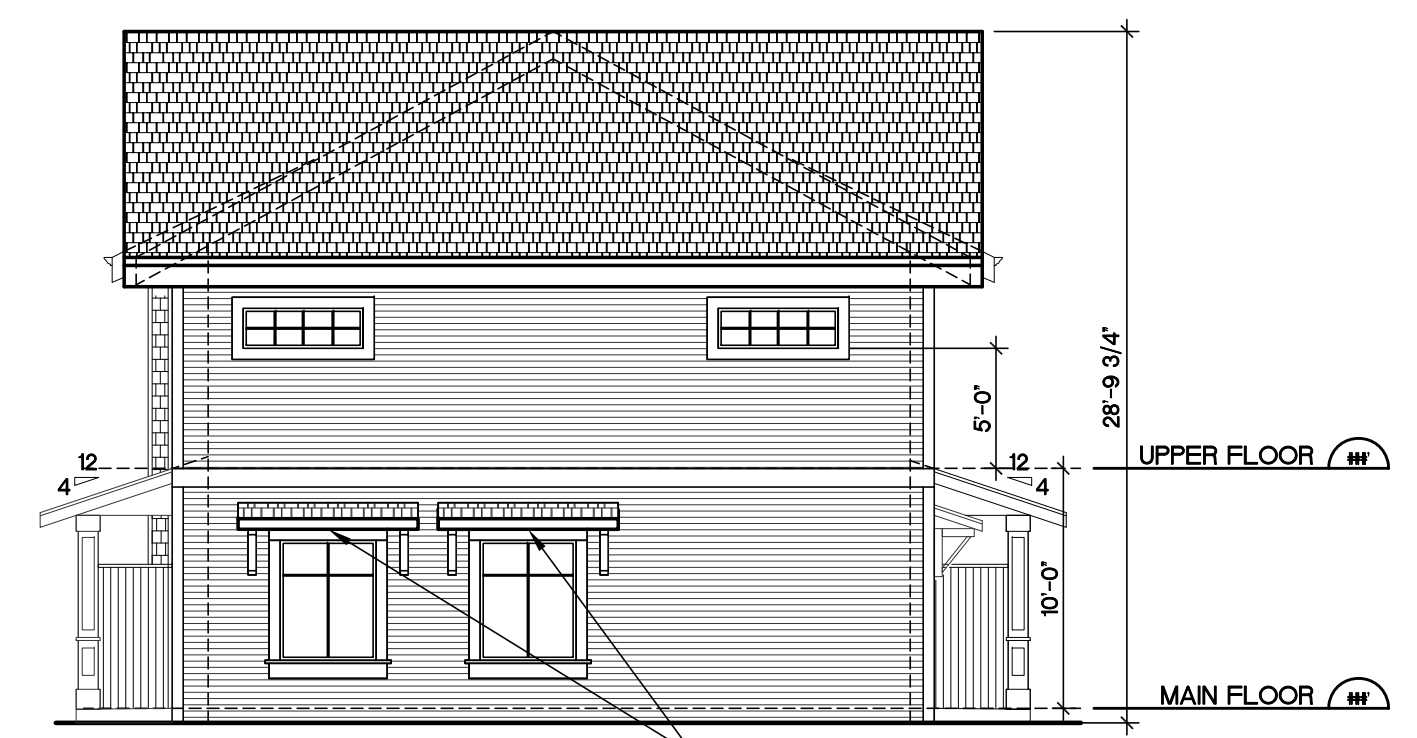

E3
A1.2 SIDE ELEVATION
SCALE: 1/8" = 1'-0"

SHED ROOF ON WEST SIDE OF BUILDING 3 AND EAST SIDE OF BUILDING 4 ONLY



TYPE B SOUTH (REAR) ELEVATION

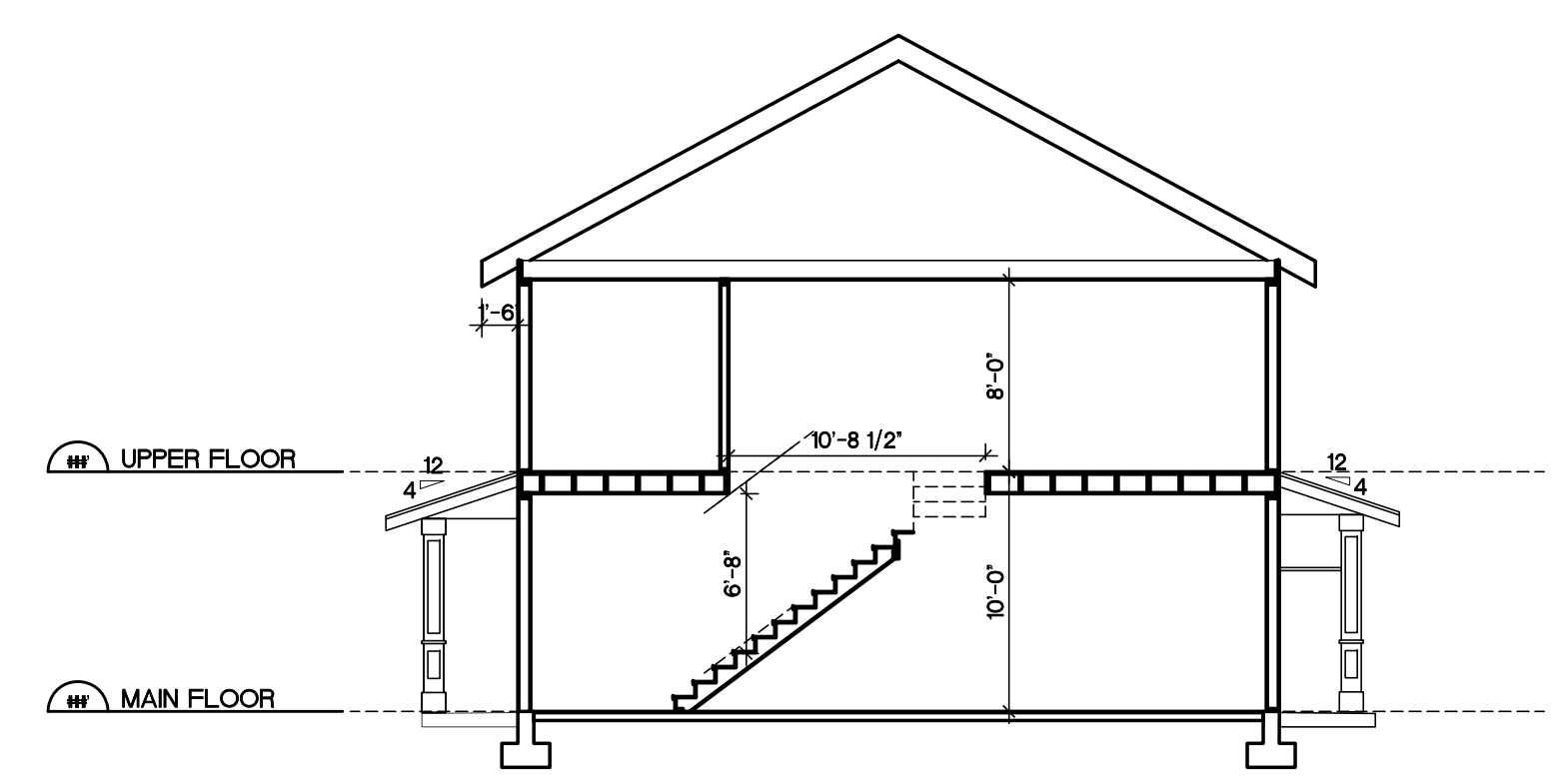

COPYRIGHT RESERVED. ALL PARTS OF THIS DRAWING ARE THE EXCLUSIVE PROPERTY OF ANDREW TERRETT ARCHITECT & ASSOCIATES AND SHALL NOT BE USED WITHOUT THE ARCHITECT'S CONSENT. THE CONTRACTOR SHALL REPORT ALL ERRORS AND OMISSIONS TO THE ARCHITECT, AND VERIFY ALL DIMENSIONS ON SITE BEFORE PROCEEDING WITH THE WORK. DO NOT SCALE DRAWINGS.

REVISIONS:

rev.	date	description
1	FEB 07/11	CONSULTANT COORDINATION
2	MAR 04/11	DEVELOPMENT PERMIT
3	APR 12/11	DEVELOPMENT PERMIT AMENDMENT
4		
5		
6		
7		
8		

SEAL:

CONSULTANT:

PROJECT:

1720 Dufferin Crescent
NANAIMO, BC

SHEET TITLE:

**BUILDING 6 AND 7
TYPE C1**

CHECKED BY: AT

DRAWN BY: CV

DATE: JAN 12/11

SCALE: 1/8" = 1'-0"

PROJECT NO. DRAWING NO.

A1.3

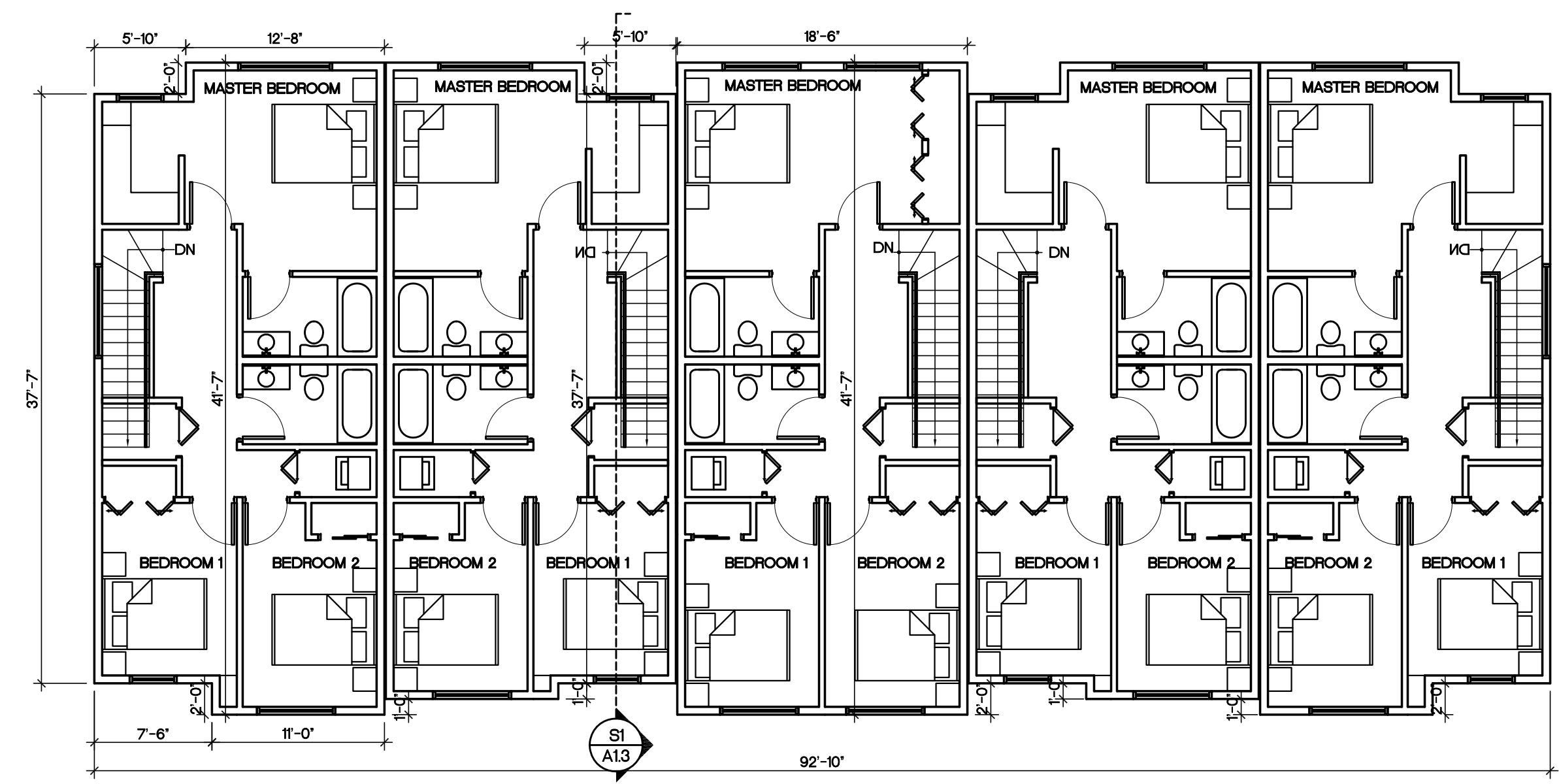

P2
A1.3 2ND FLOOR PLAN
SCALE: 1/8" = 1'-0"

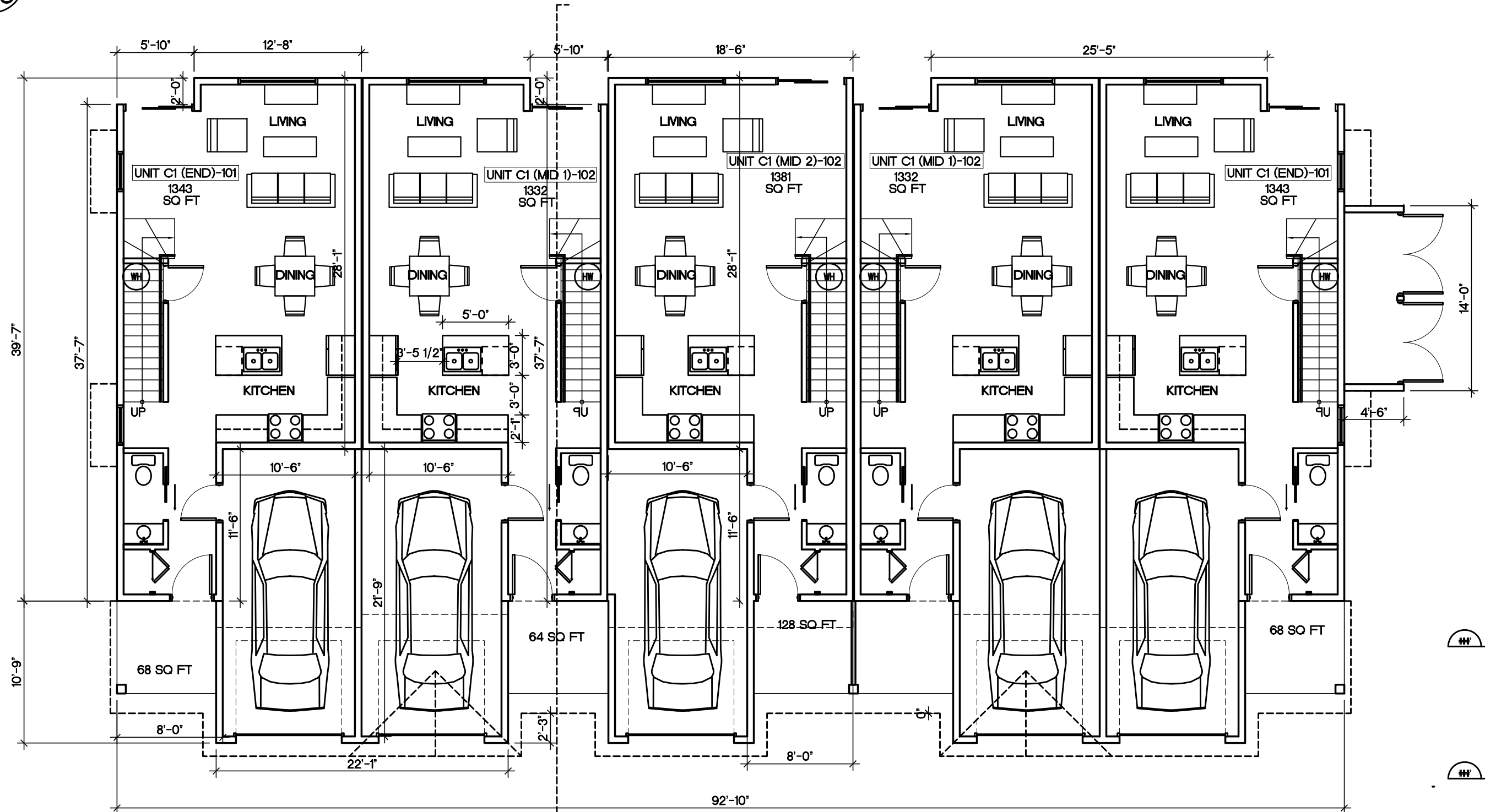

P1
A1.3 MAIN FLOOR PLAN
SCALE: 1/8" = 1'-0"



E3
A1.5 REAR ELEVATION
SCALE: 1/8" = 1'-0"



E1
A1.4 FRONT ELEVATION
SCALE: 1/8" = 1'-0"



E2
A1.4 SIDE ELEVATION
SCALE: 1/8" = 1'-0"

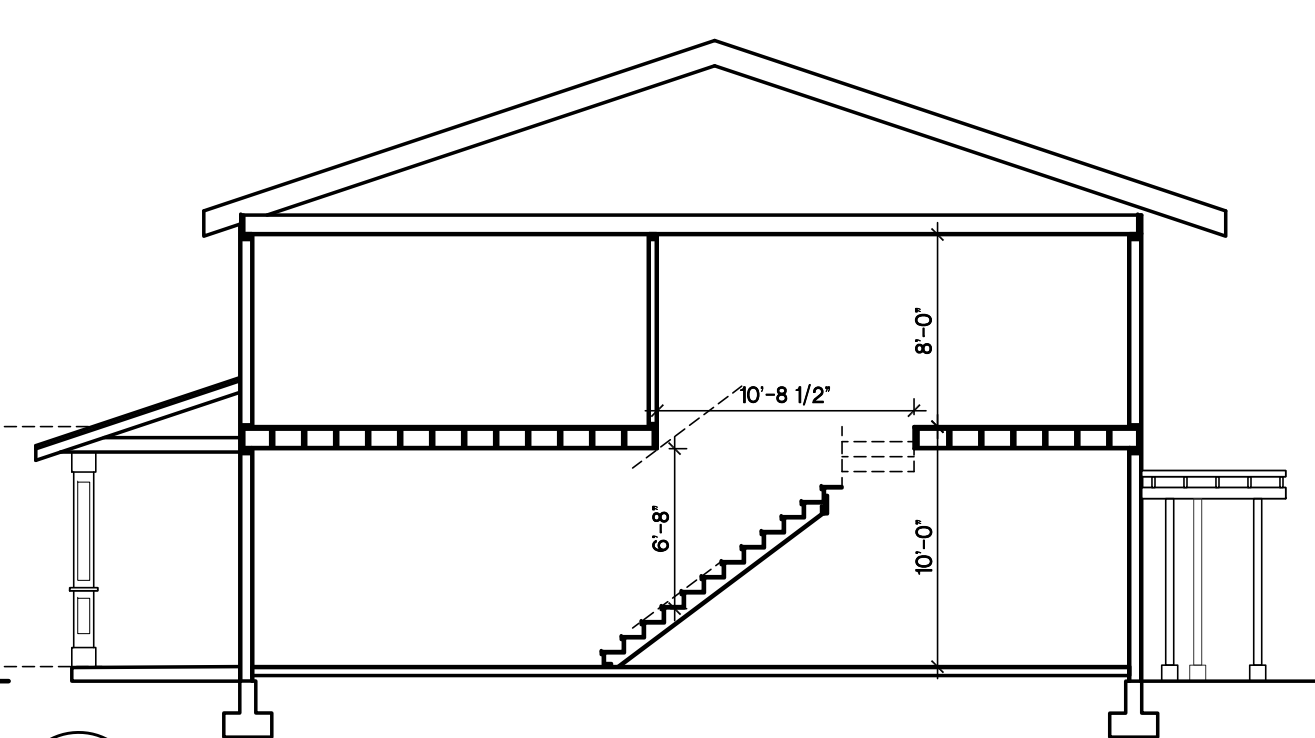

S1
A1.3 SECTION
SCALE: 1/8" = 1'-0"

COPYRIGHT RESERVED. ALL PARTS OF THIS DRAWING ARE THE EXCLUSIVE PROPERTY OF ANDREW TERRETT ARCHITECT & ASSOCIATES AND SHALL NOT BE USED WITHOUT THE ARCHITECT'S CONSENT. THE CONTRACTOR SHALL REPORT ALL ERRORS AND OMISSIONS TO THE ARCHITECT, AND VERIFY ALL DIMENSIONS ON SITE BEFORE PROCEEDING WITH THE WORK. DO NOT SCALE DRAWINGS.

REVISIONS:

rev.	date	description
1	FEB 07/11	CONSULTANT COORDINATION
2	MAR 04/11	DEVELOPMENT PERMIT
3	APR 12/11	DEVELOPMENT PERMIT AMENDMENT
4		
5		
6		
7		
8		

SEAL:

CONSULTANT:

PROJECT:

1720 Dufferin Crescent
NANAIMO, BC

SHEET TITLE:

BUILDING 9, 12 AND 15
TYPE C2

CHECKED BY: AT

DRAWN BY: CV

DATE: JAN 12/11

SCALE: 1/8" = 1'-0"

PROJECT NO. DRAWING NO.

A1.4

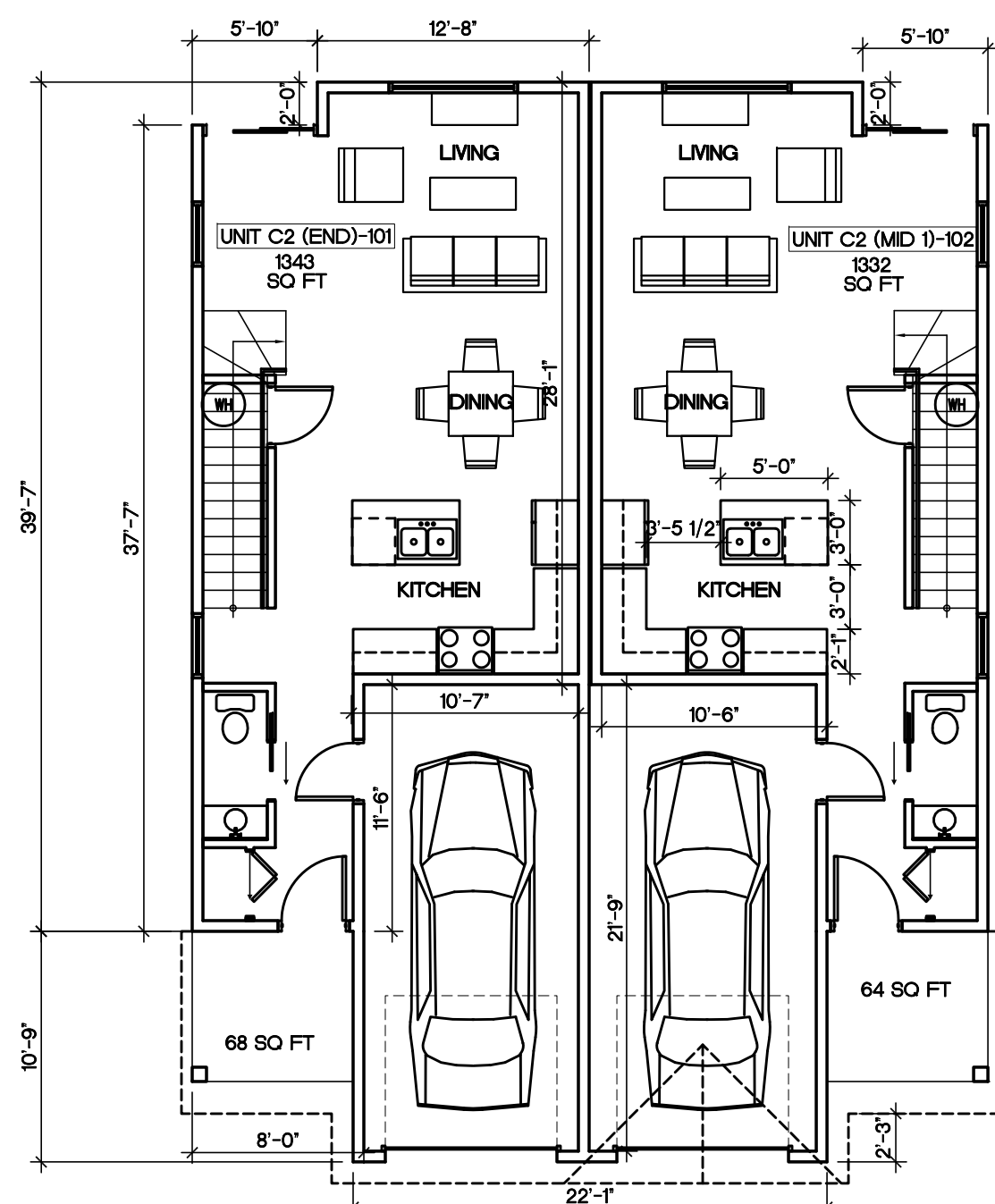

P1 MAIN FLOOR PLAN
SCALE: 1/8" = 1'-0"

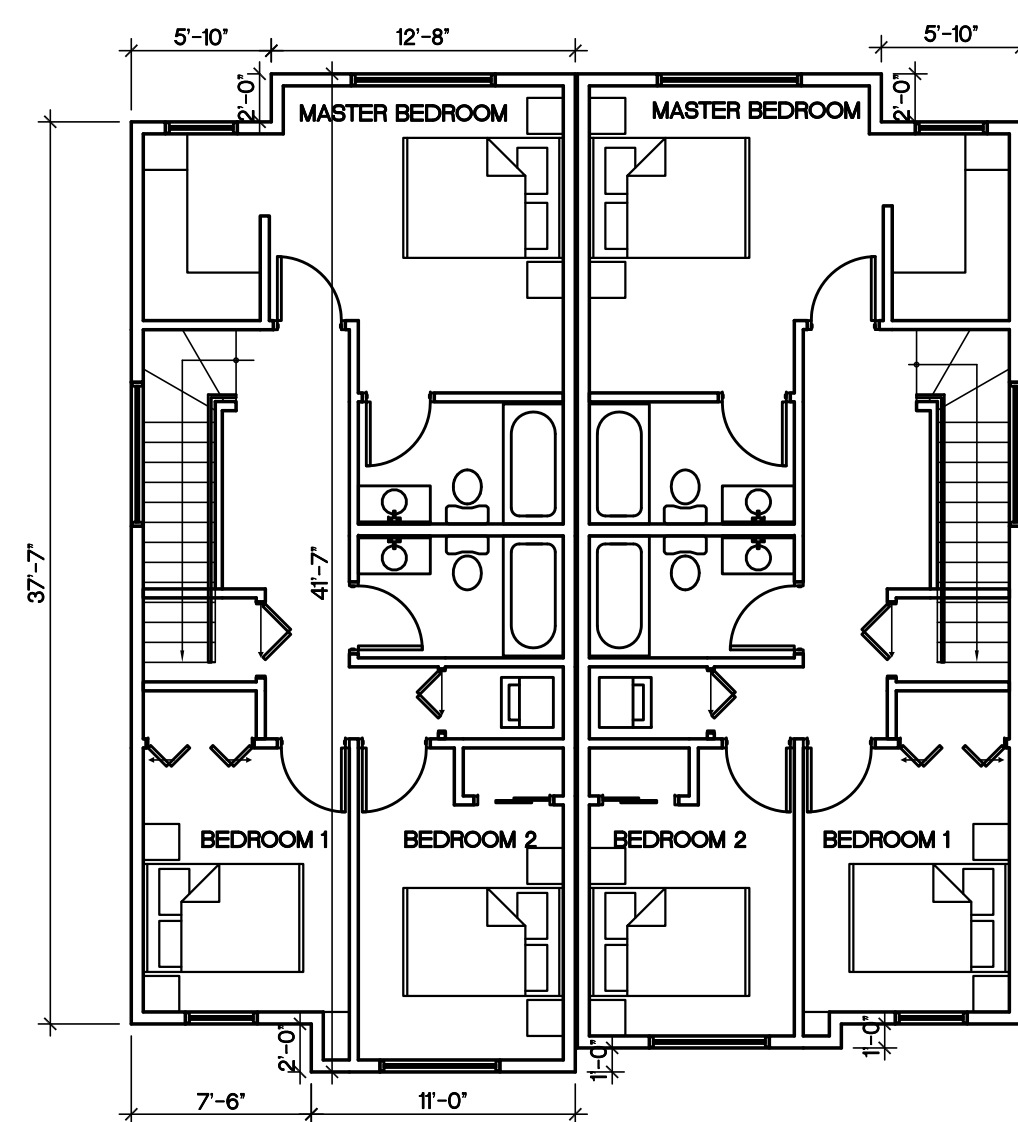

P2 2ND FLOOR PLAN
SCALE: 1/8" = 1'-0"



E1 FRONT ELEVATION
SCALE: 1/8" = 1'-0"

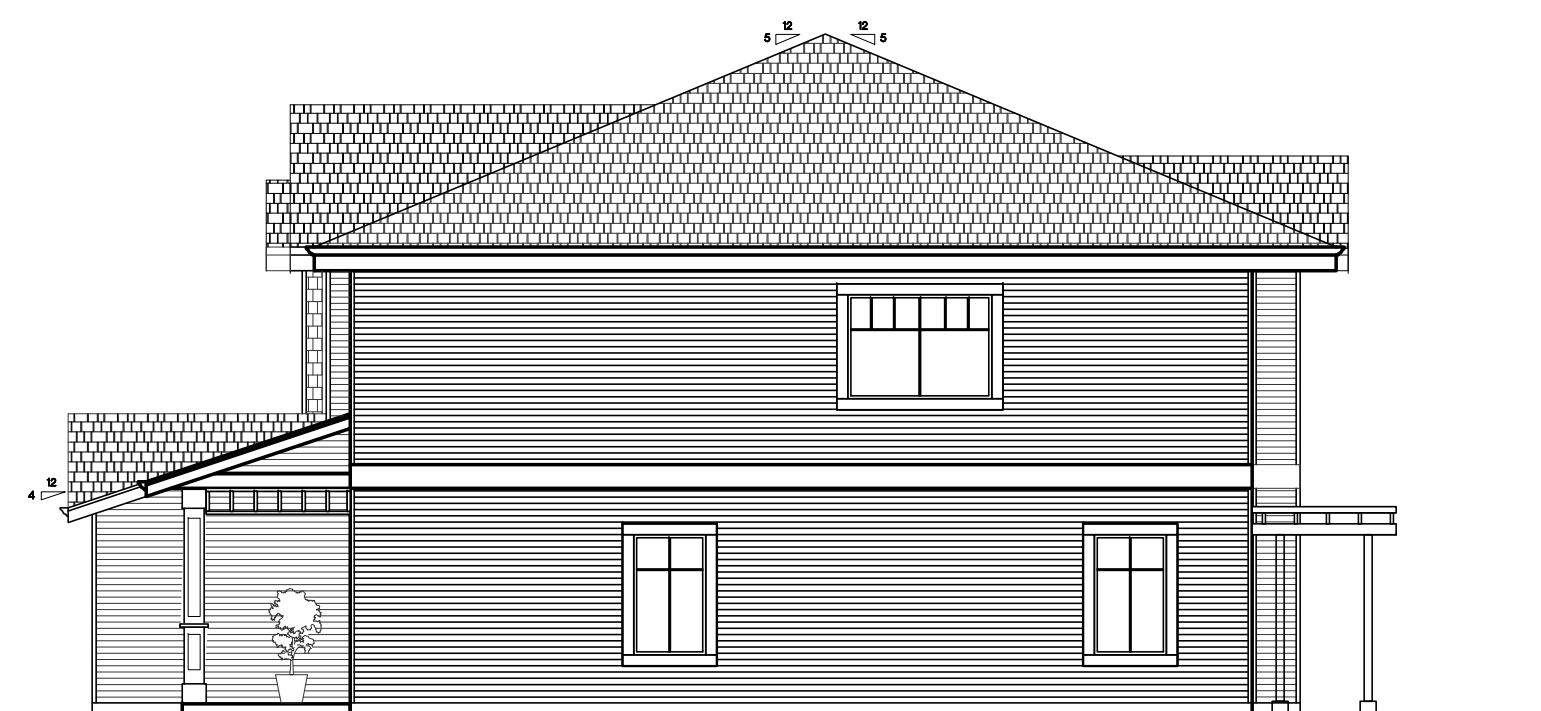

E2 SIDE ELEVATION
SCALE: 1/8" = 1'-0"



E3 REAR ELEVATION
SCALE: 1/8" = 1'-0"

COPYRIGHT RESERVED. ALL PARTS OF THIS DRAWING ARE THE EXCLUSIVE PROPERTY OF ANDREW TERRETT ARCHITECT & ASSOCIATES AND SHALL NOT BE USED WITHOUT THE ARCHITECT'S CONSENT. THE CONTRACTOR SHALL REPORT ALL ERRORS AND OMISSIONS TO THE ARCHITECT, AND VERIFY ALL DIMENSIONS ON SITE BEFORE PROCEEDING WITH THE WORK. DO NOT SCALE DRAWINGS.

REVISIONS:

rev.	date	description
1	FEB 07/11	CONSULTANT COORDINATION
2	MAR 04/11	DEVELOPMENT PERMIT
3		
4		
5		
6		
7		
8		

SEAL:

CONSULTANT:

PROJECT:

1720 Dufferin Crescent
NANAIMO, BC

SHEET TITLE:

BUILDING 17 - 22
TYPE F

CHECKED BY: AT

DRAWN BY: CV

DATE: JAN 12/11

SCALE: 1/8" = 1'-0"

PROJECT NO. DRAWING NO.

A1.6

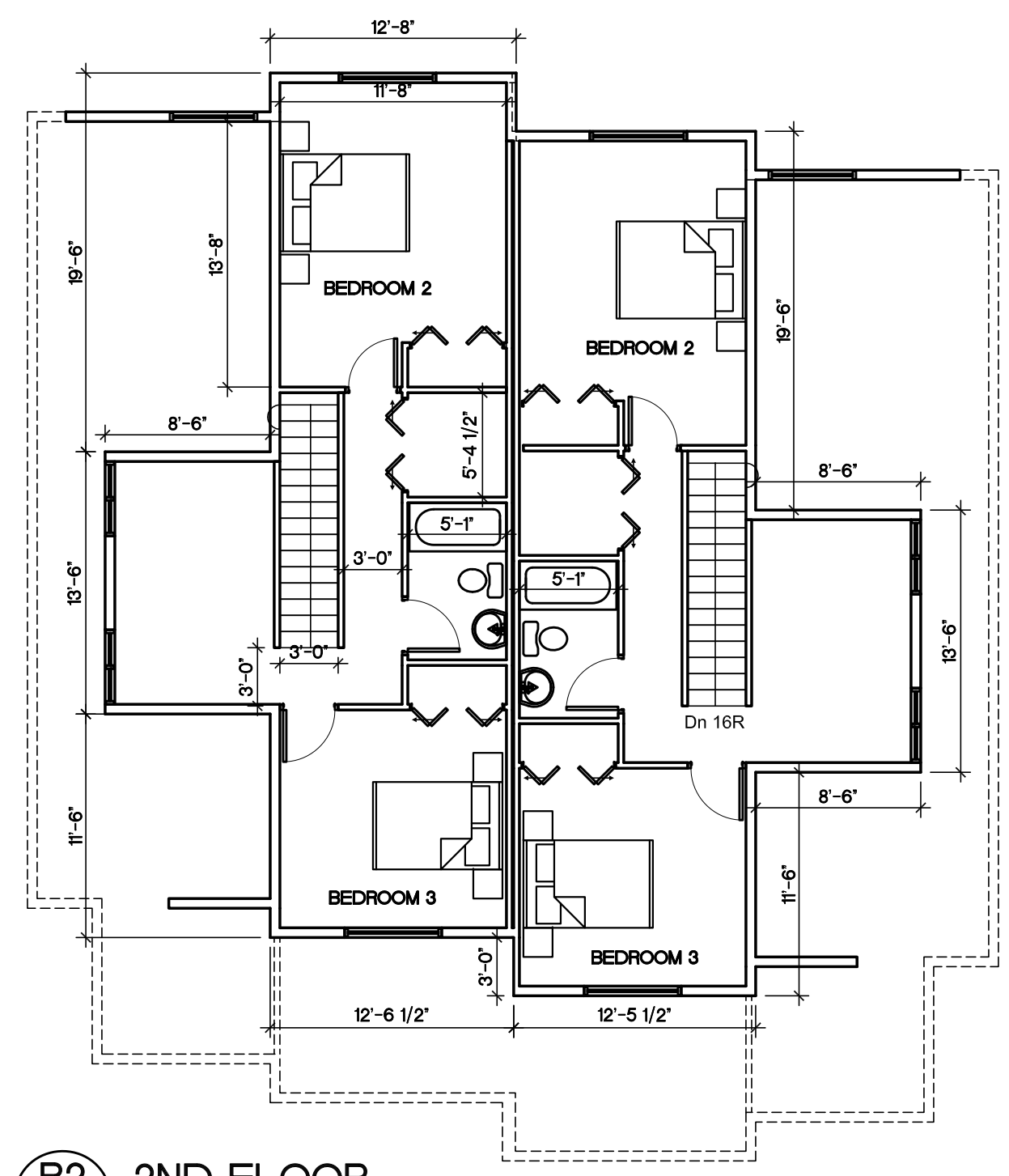

P2 2ND FLOOR
A1.6 SCALE: 1/8" = 1'-0"

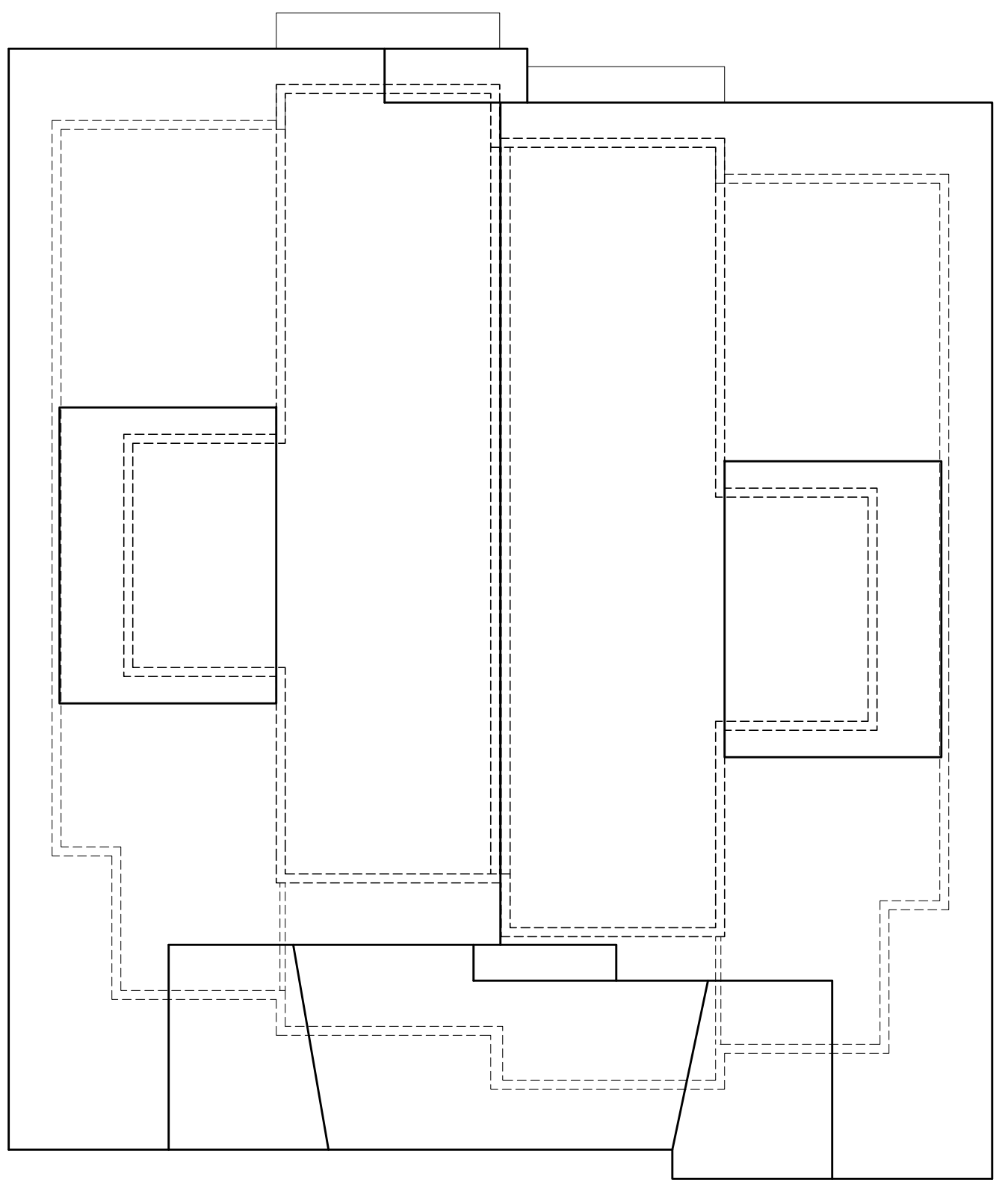

P3 ROOF PLAN
A1.6 SCALE: 1/8" = 1'-0"

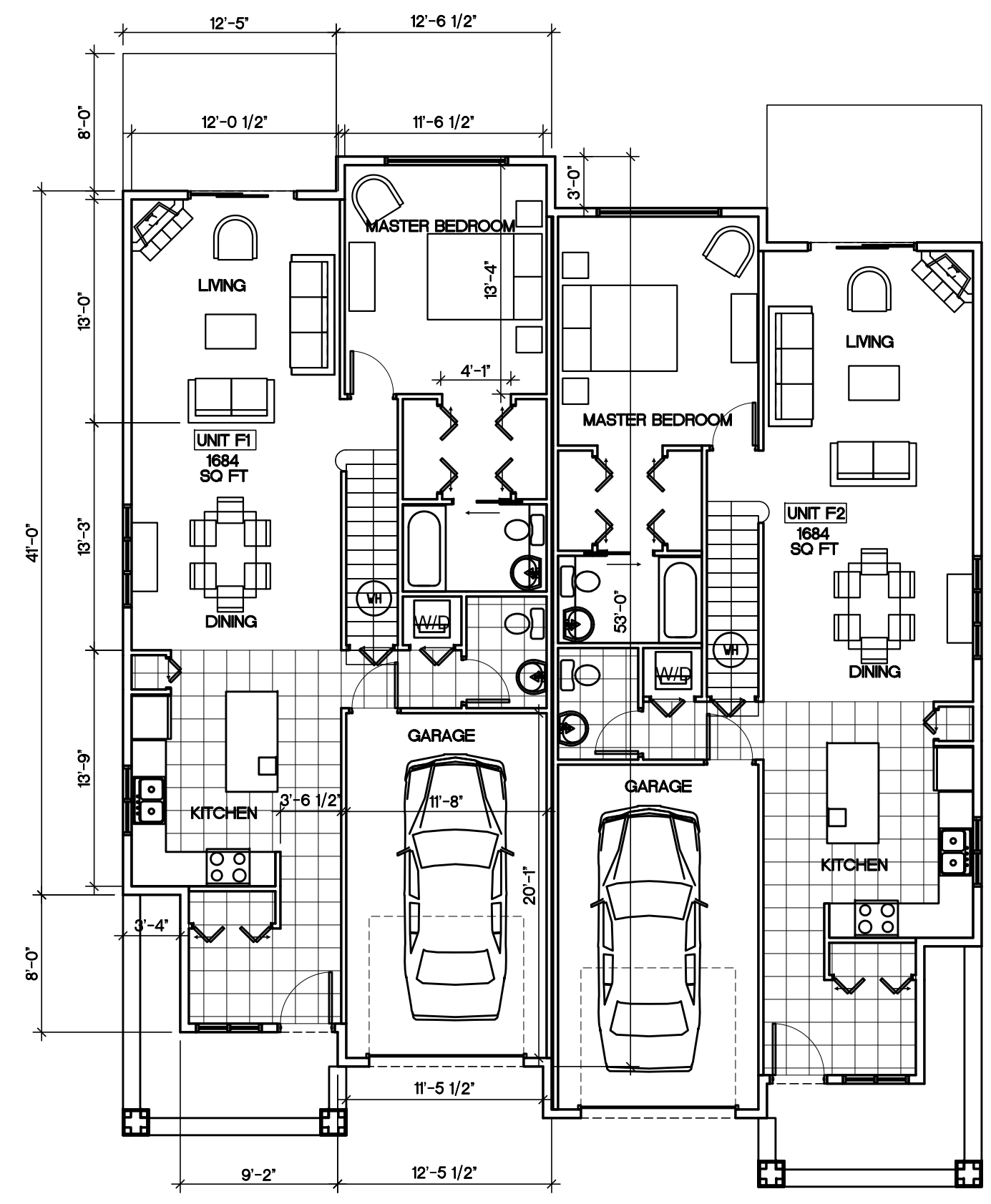

P1 MAIN FLOOR
A1.6 SCALE: 1/8" = 1'-0"

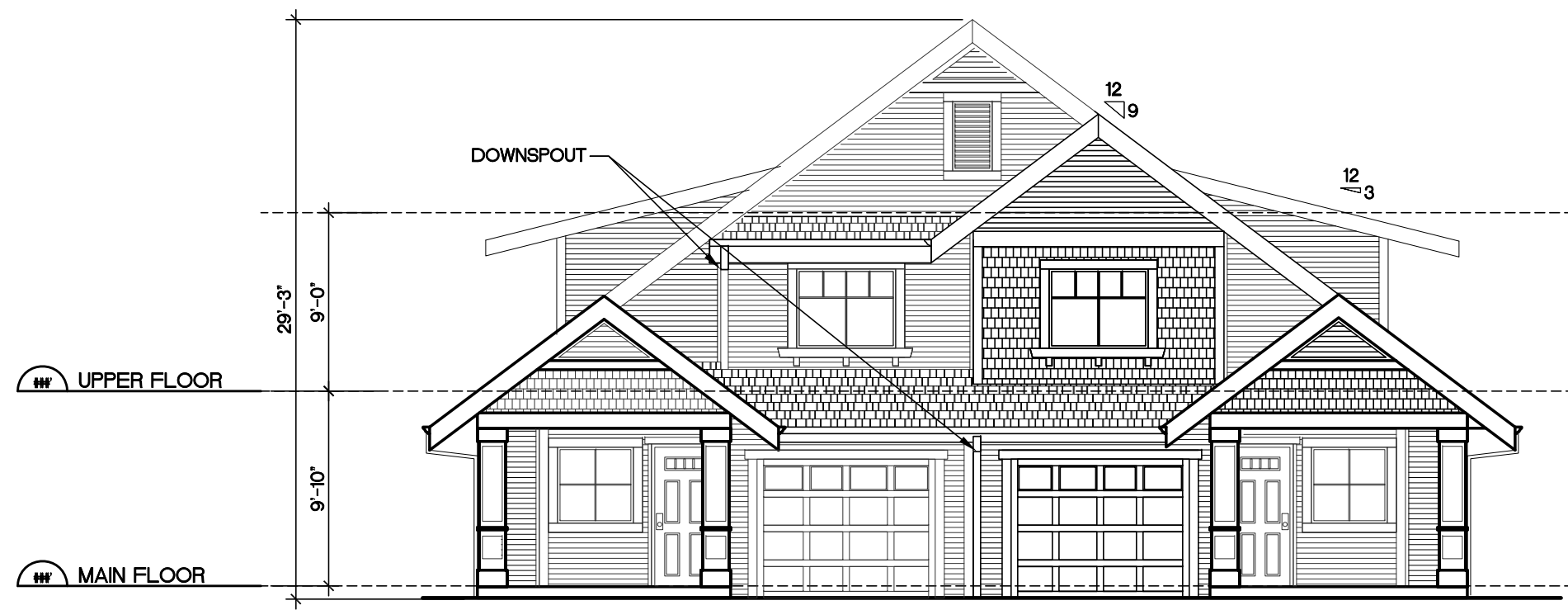

E1 FRONT ELEVATION
A1.6 SCALE: 1/8" = 1'-0"

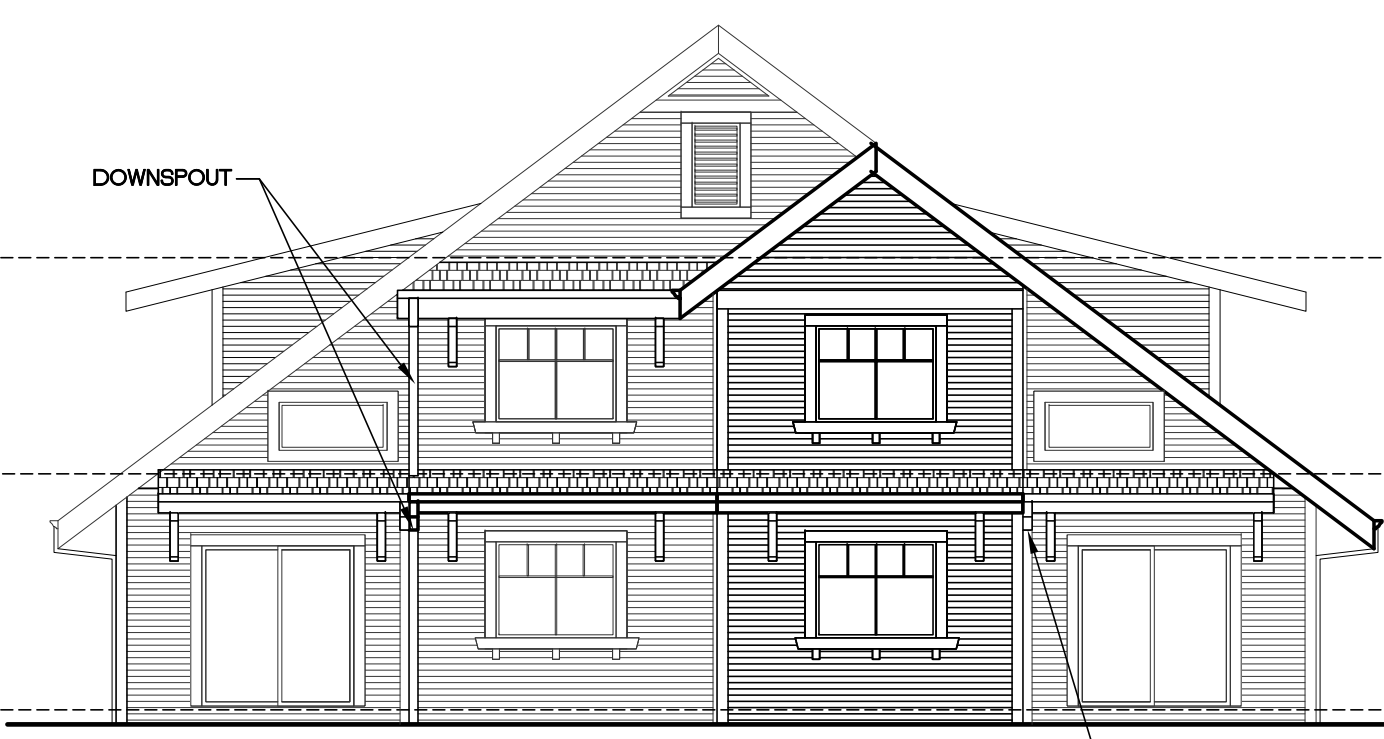

E2 REAR ELEVATION
A1.6 SCALE: 1/8" = 1'-0"

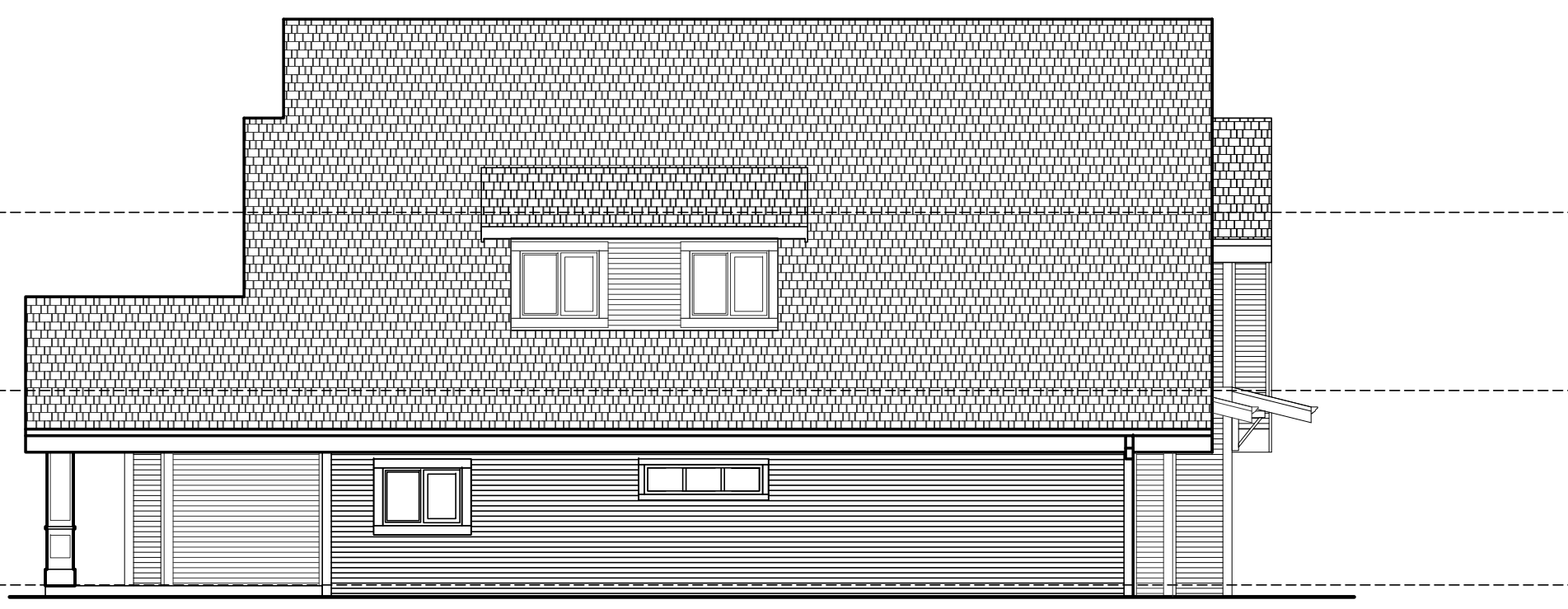

E3 SIDE ELEVATION
A1.6 SCALE: 1/8" = 1'-0"

COPYRIGHT RESERVED. ALL PARTS OF THIS DRAWING ARE THE EXCLUSIVE PROPERTY OF ANDREW TERRETT ARCHITECT & ASSOCIATES AND SHALL NOT BE USED WITHOUT THE ARCHITECT'S CONSENT. THE CONTRACTOR SHALL REPORT ALL ERRORS AND OMISSIONS TO THE ARCHITECT, AND VERIFY ALL DIMENSIONS ON SITE BEFORE PROCEEDING WITH THE WORK. DO NOT SCALE DRAWINGS.

REVISIONS:

rev.	date	description
1	FEB 07/11	CONSULTANT COORDINATION
2	MAR 04/11	DEVELOPMENT PERMIT
3		
4		
5		
6		
7		
8		

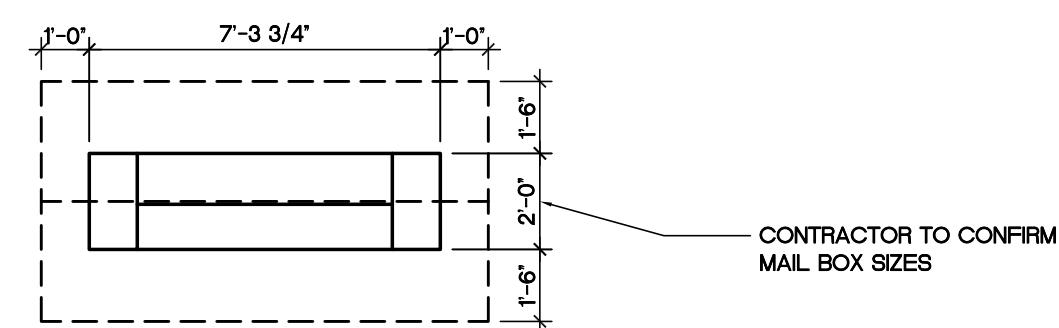

MAIL BOX - PLAN

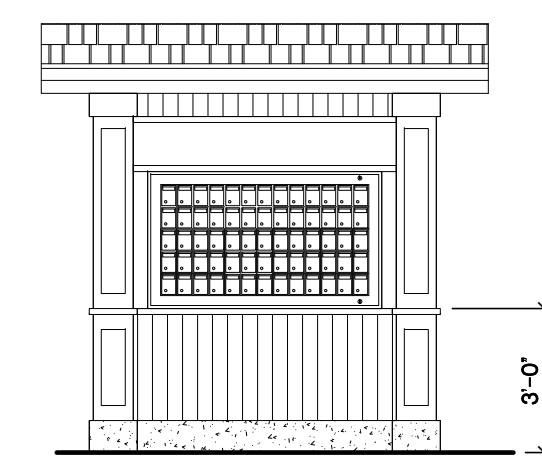

MAIL BOX - FRONT ELEV

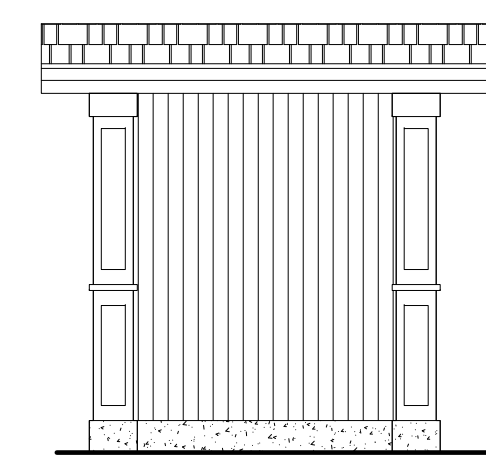

MAIL BOX - REAR ELEV

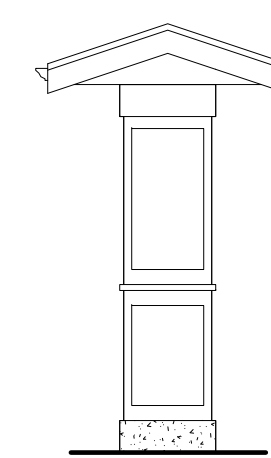

MAIL BOX - SIDE ELEV

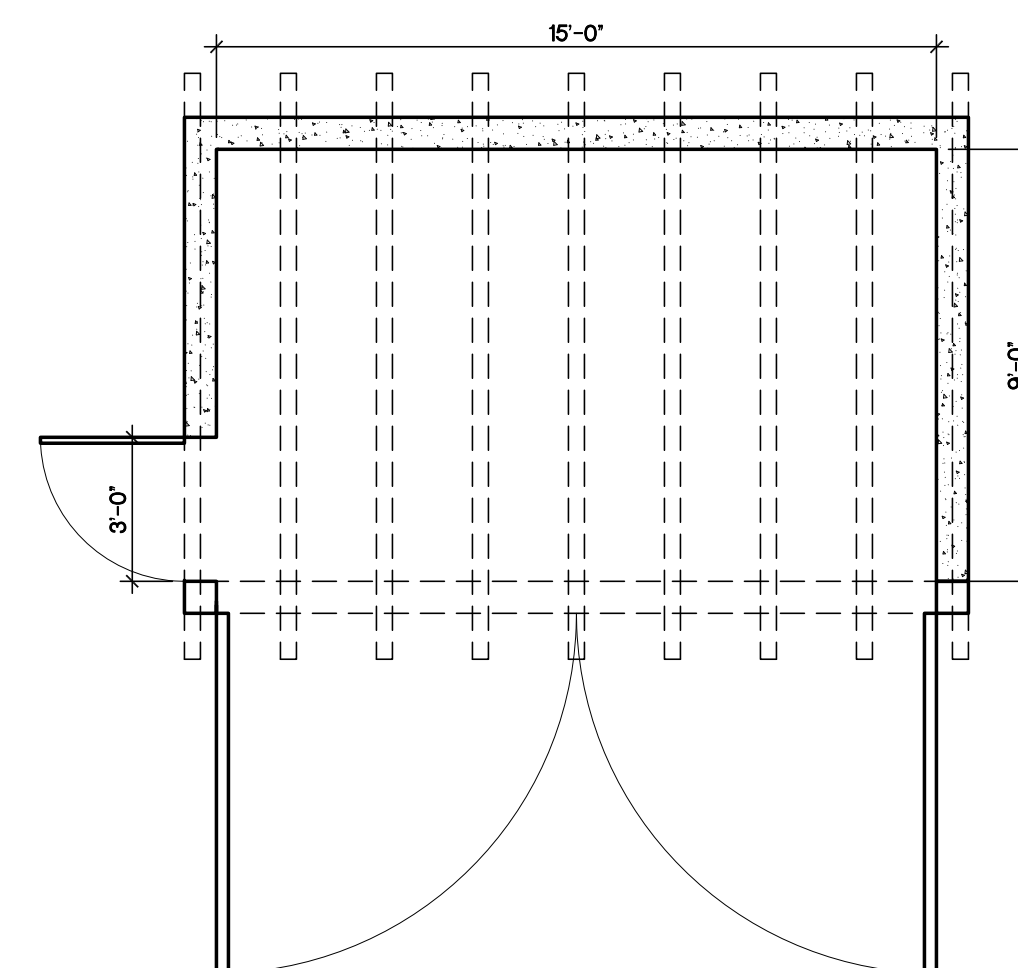

REFUSE ENCLOSURE - PLAN

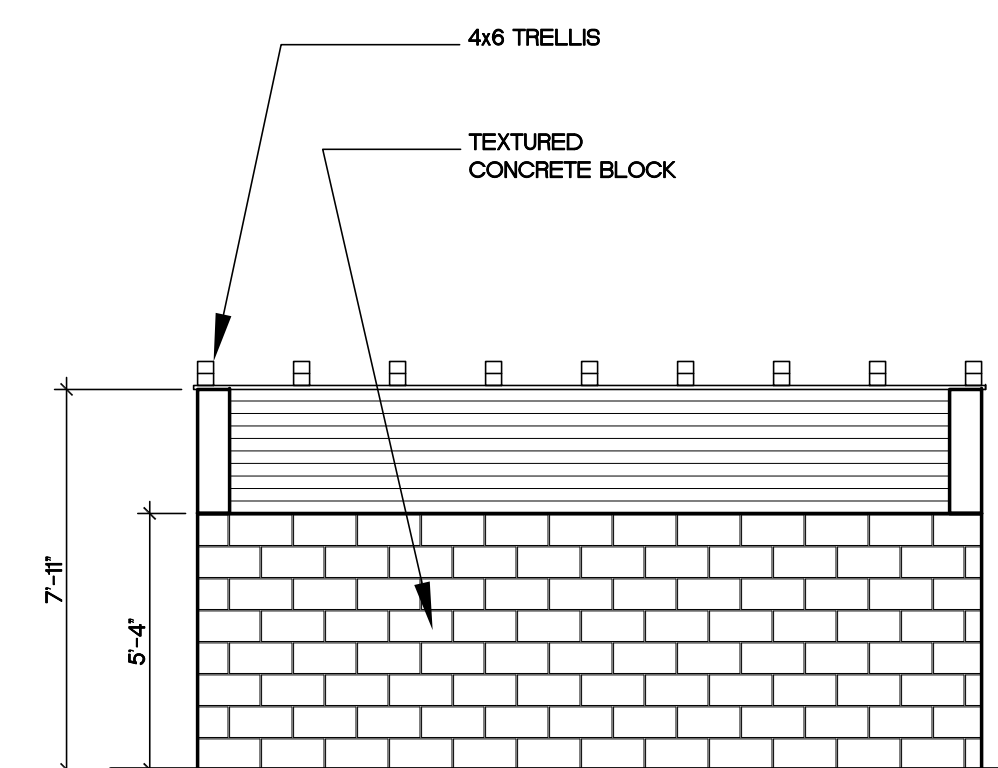

REFUSE ENCLOSURE - REAR ELEVATION

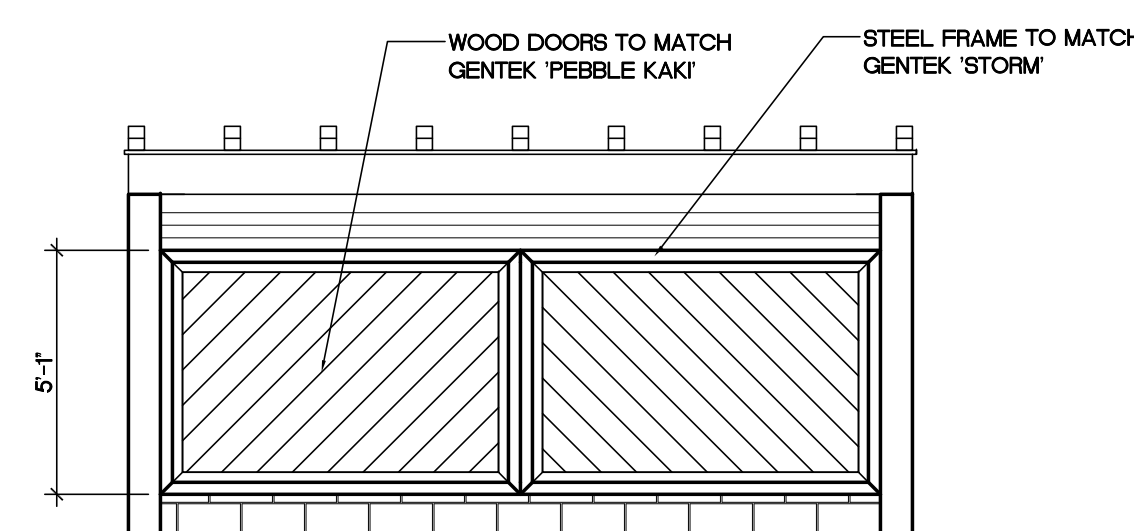

REFUSE ENCLOSURE - FRONT ELEVATION

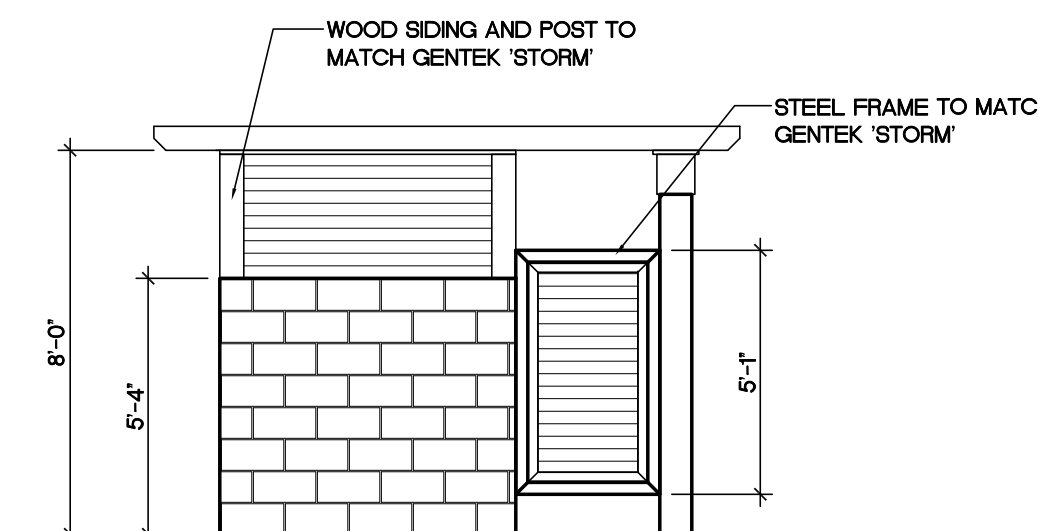

REFUSE ENCLOSURE - SIDE ELEVATION

SEAL:

CONSULTANT:

PROJECT:
1720 Dufferin Crescent
NANAIMO, BC

SHEET TITLE:
MAIL BOX
GARBAGE ENCLOSURE

CHECKED BY: AT

DRAWN BY: CV

DATE: JAN 12/11

SCALE: 1/8" = 1'-0"

PROJECT NO. DRAWING NO.

A1.7